

70 UNION STREET DULWICH HILL

PROPOSED ALTERNATIONS AND ADDITIONS



INDEX:

- 00 - TITLE PAGE
- 01 - EXISTING AND PROPOSED SITE PLAN
- 02 - EXISTING FLOOR PLAN
- 03 - DEMOLITION PLAN
- 04 - PROPOSED FLOOR PLAN
- 04 A - SLAB SET OUT
- 04 B - FLOOR PLAN - CONSTRUCTION DETAILS
- 05 - ELEVATIONS
- 06 A - SECTIONS
- 06 B - SECTIONS
- 06 C - DETAIL SECTIONS
- 07 - ROOF PLAN
- 08 - WINDOW AND DOOR SCHEDULE & BASIX
- 09 - BATHROOM ELEVATIONS
- 10 - ELECTRICAL PLAN

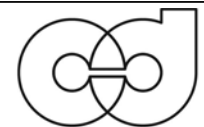

connected
design

FOR CONSTRUCTION



TRACY GRAHAM
12 PETERSHAM ROAD,
MARRICKVILLE, NSW, 2204
MOBILE 0405 431119
tracy@connecteddesign.com.au

Gwen and Richard Ng

70 Union Street Dulwich Hill

Title Page

Project number	G03
Date	03/08/21
Drawn by	CC
Version	C01

00

Scale @A3

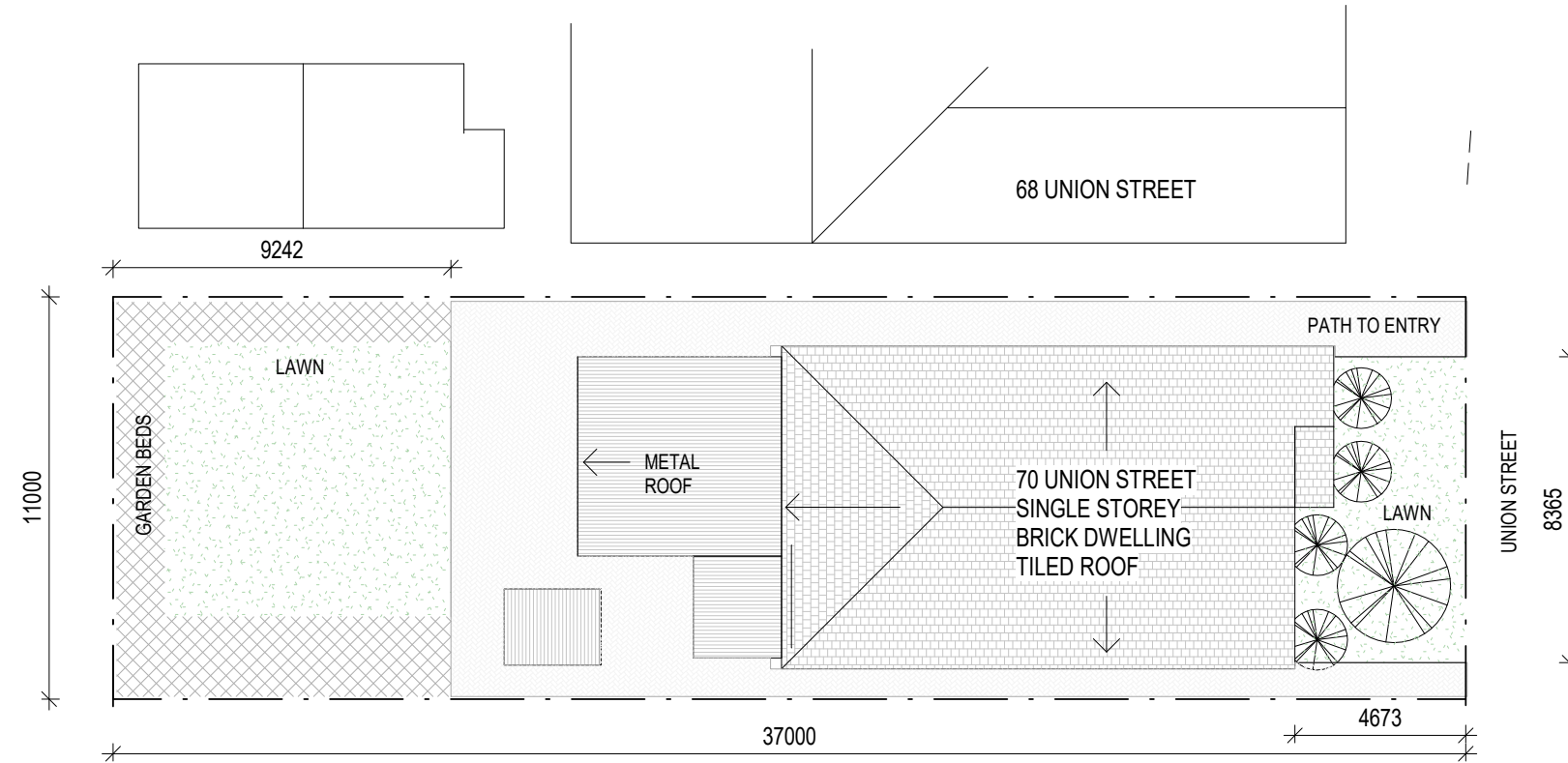

1 Site
1 : 200

LOT 3 SECTION 2
DP 9501
R2 - LOW DENSITY RESIDENTIAL
SITE AREA: 401m²
FSR 0.6:1

EXISTING GFA: 130m²
EXISTING FSR: 0.3:1

LANDSCAPING
EXISTING: 133m² (99m² BEHIND FRONT SETBACK)

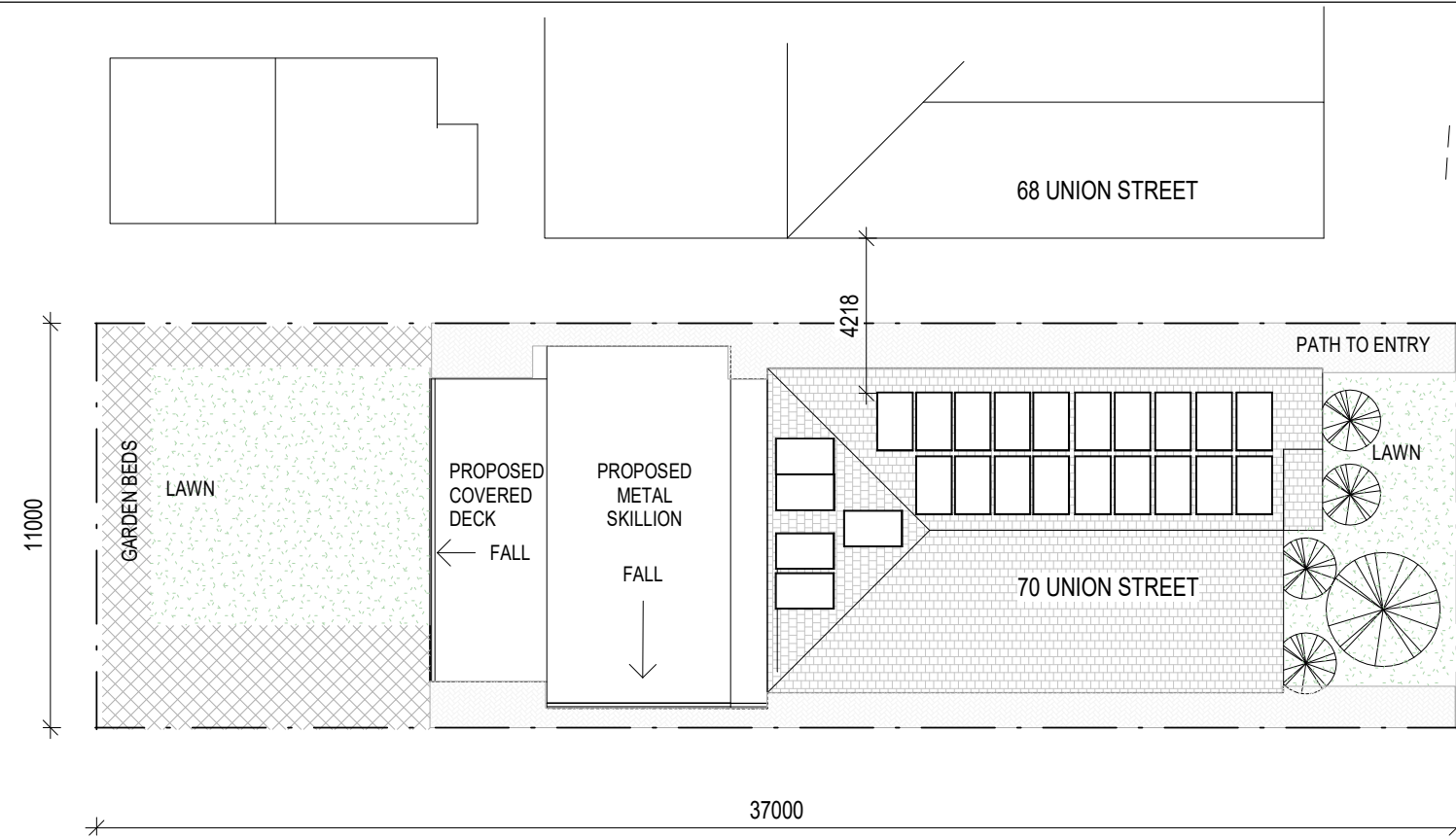

2 Site - Proposed
1 : 200

PROPOSED GFA: 142m²
PROPOSED FSR: 0.3:1

LANDSCAPING
PROPOSED: 133m² (NO CHANGE)



FOR CONSTRUCTION



TRACY GRAHAM
12 PETERSHAM ROAD,
MARRICKVILLE, NSW, 2204
MOBILE 0405 431119
tracy@connecteddesign.com.au

Gwen and Richard Ng

70 Union Street Dulwich Hill

Site Plan

Project number	G03
Date	03/08/21
Drawn by	CC
Version	C01

01

Scale @A3 1 : 200

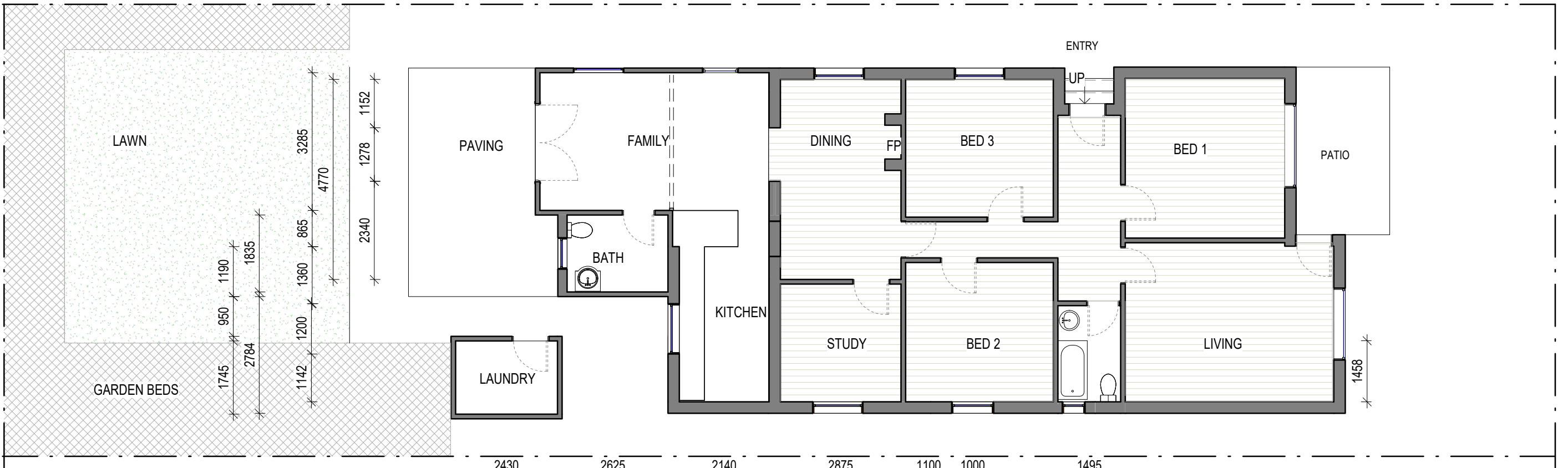
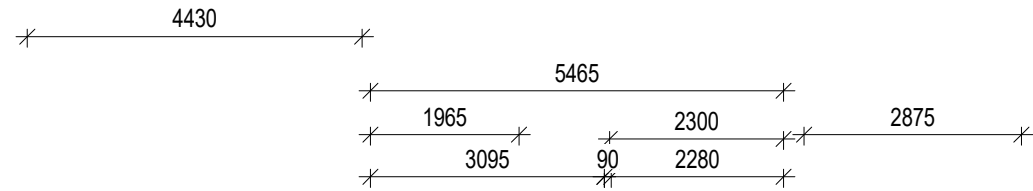

1 Ground Floor - Existing
1 : 100

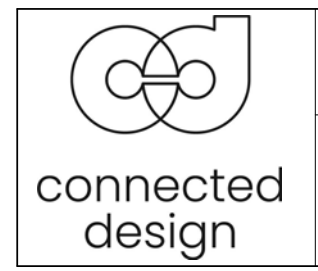

FOR CONSTRUCTION

bdca
ACCREDITED
BUILDING DESIGNER

TRACY GRAHAM
12 PETERSHAM ROAD,
MARRICKVILLE, NSW, 2204
MOBILE 0405 431119
tracy@connecteddesign.com.au

Gwen and Richard Ng

70 Union Street Dulwich Hill

Existing Floor Plan			02
Project number	G03		
Date	03/08/21		
Drawn by	CC		
Version	C01		Scale @A3 1 : 100

- NOTE: PRIOR TO ANY CONSTRUCTION WORK COMMENCING
- ALL WORK MUST COMPLY WITH NCC
 - CONFIRM ALL DIMENSIONS ON SITE PRIOR TO CONSTRUCTION
 - ANY CONFLICTS MUST BE BROUGHT TO THE ATTENTION OF THE DESIGNER
 - DO NOT MEASURE FROM THE PLANS

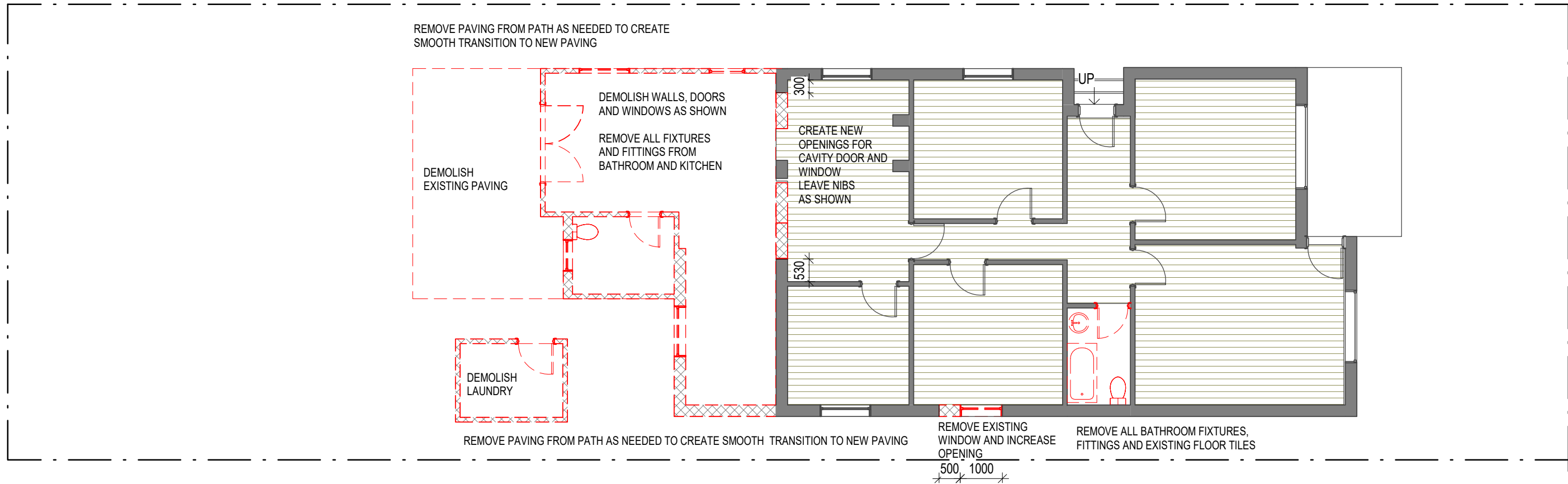
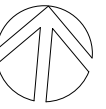

1 **Ground Floor - Demolition**
1 : 100

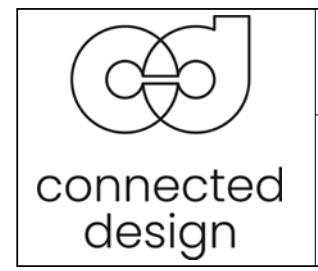

FOR CONSTRUCTION

bdaa
ACCREDITED
BUILDING DESIGNER

TRACY GRAHAM
12 PETERSHAM ROAD,
MARRICKVILLE, NSW, 2204
MOBILE 0405 431119
tracy@connecteddesign.com.au

Gwen and Richard Ng

70 Union Street Dulwich Hill

Demolition Plan		
Project number	G03	03
Date	03/08/21	
Drawn by	CC	
Version	C01	
Scale @A3		1 : 100

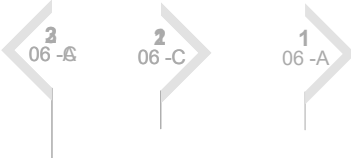
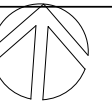

EXTERNAL WALLS 90MM TIMBER FRAME WITH HEMCRETE CLADDING

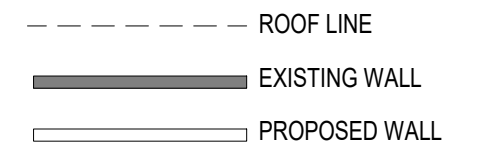
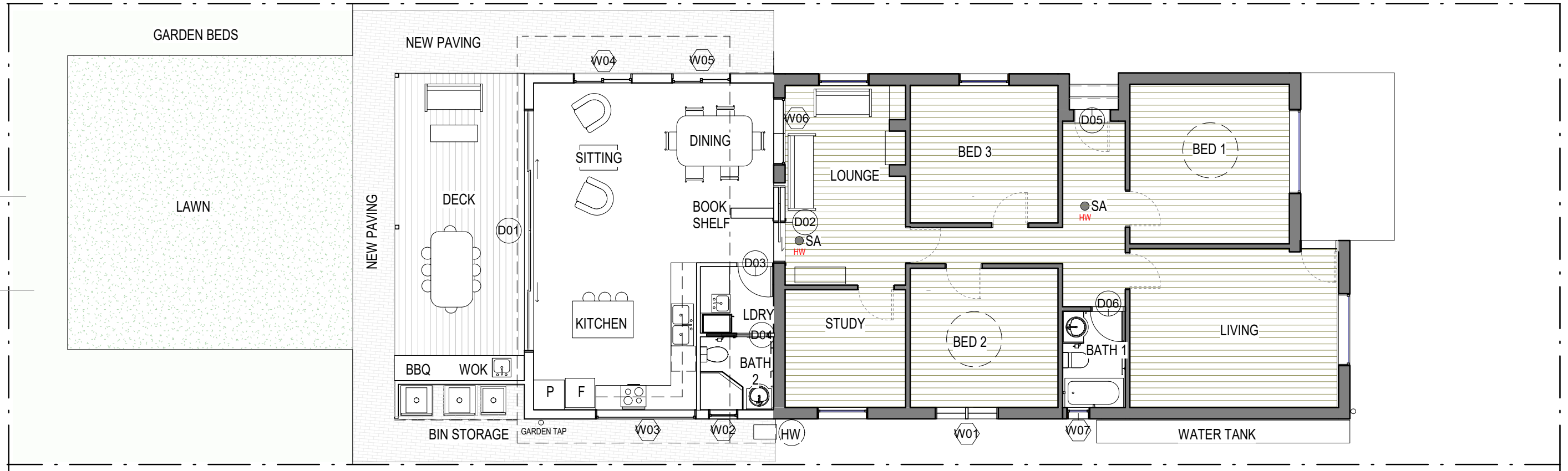

1 Ground Floor -Proposed
1 : 100



BASIX REQUIREMENTS:

Construction	Additional insulation required (R-value)	Other specifications
concrete slab on ground floor.	nil	
external wall: other/undecided	R1.70 (including construction)	
raked ceiling, pitched/skillion roof: structural panel >100 mm	ceiling: nil (up), roof: none	medium (solar absorptance 0.475 - 0.70)

NOTE: PRIOR TO ANY CONSTRUCTION WORK COMMENCING

- ALL WORK MUST COMPLY WITH NCC
- CONFIRM ALL DIMENSIONS ON SITE PRIOR TO CONSTRUCTION
- ANY CONFLICTS MUST BE BROUGHT TO THE ATTENTION OF THE DESIGNER
- DO NOT MEASURE FROM THE PLANS

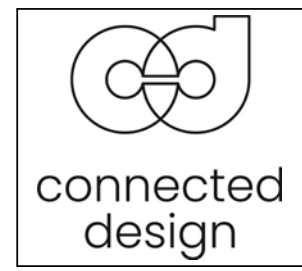

FOR CONSTRUCTION

TRACY GRAHAM
12 PETERSHAM ROAD,
MARRICKVILLE, NSW, 2204
MOBILE 0405 431119
tracy@connecteddesign.com.au

Gwen and Richard Ng

70 Union Street Dulwich Hill

Proposed Floor Plans		
Project number	G03	04
Date	03/08/21	
Drawn by	CC	
Version	C01	
Scale @A3		1 : 100

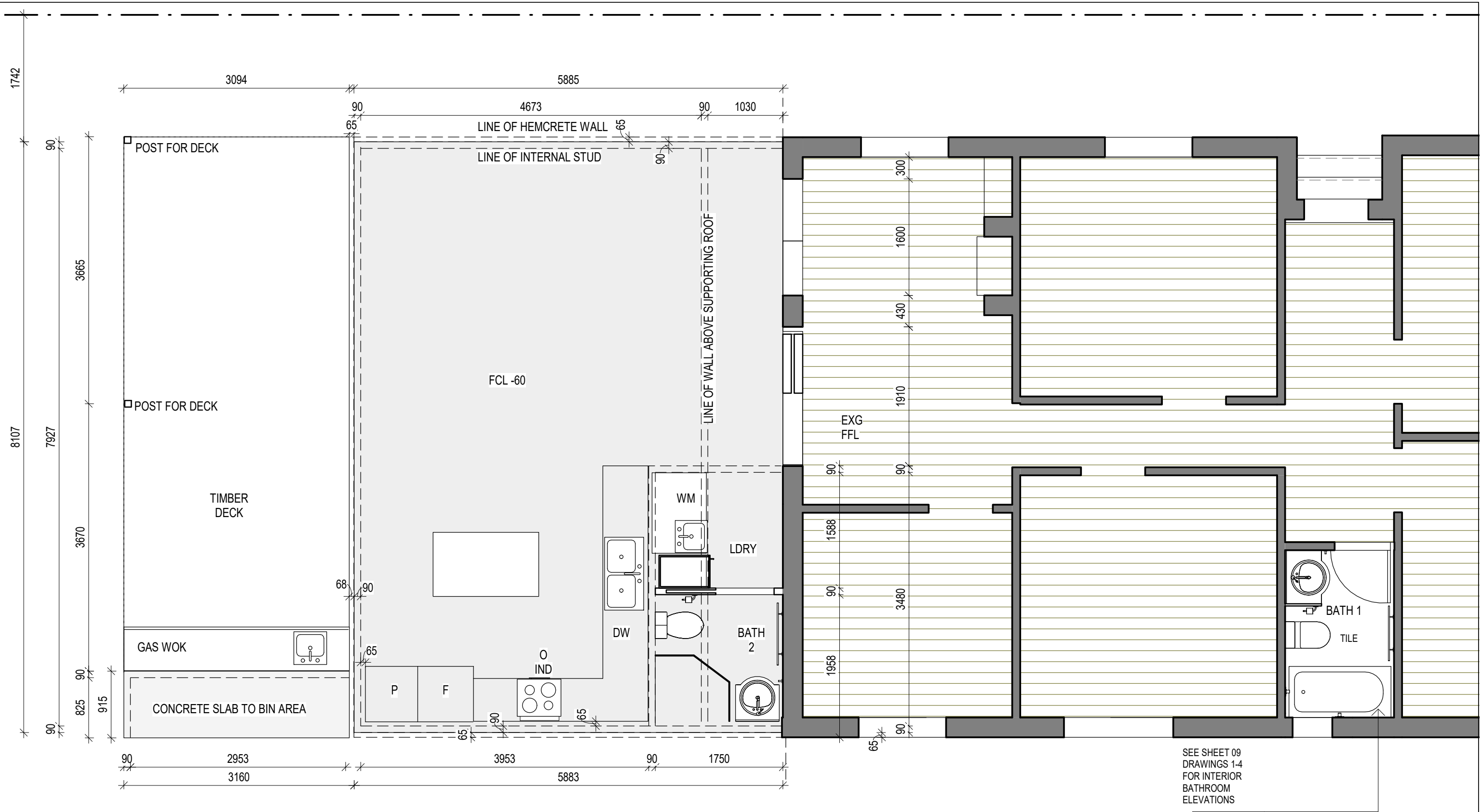

SEE SHEET 09
DRAWINGS 1-4
FOR INTERIOR
BATHROOM
ELEVATIONS

1 Ground Floor -Slab Set Out
1 : 50

	FOR CONSTRUCTION	Gwen and Richard Ng	Ground Floor - Slab Set Out									
		TRACY GRAHAM 12 PETERSHAM ROAD, MARRICKVILLE, NSW, 2204 MOBILE 0405 431119 tracy@connecteddesign.com.au	70 Union Street Dulwich Hill	<table border="1"> <tr> <td>Project number</td> <td>G03</td> <td rowspan="4" style="text-align: center; vertical-align: middle;">04- A</td> </tr> <tr> <td>Date</td> <td>03/08/21</td> </tr> <tr> <td>Drawn by</td> <td>CC</td> </tr> <tr> <td>Version</td> <td>C01</td> </tr> </table>	Project number	G03	04- A	Date	03/08/21	Drawn by	CC	Version
Project number	G03	04- A										
Date	03/08/21											
Drawn by	CC											
Version	C01											
		Scale @A3		1 : 50								

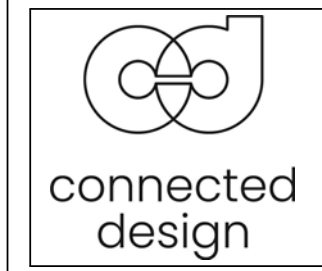
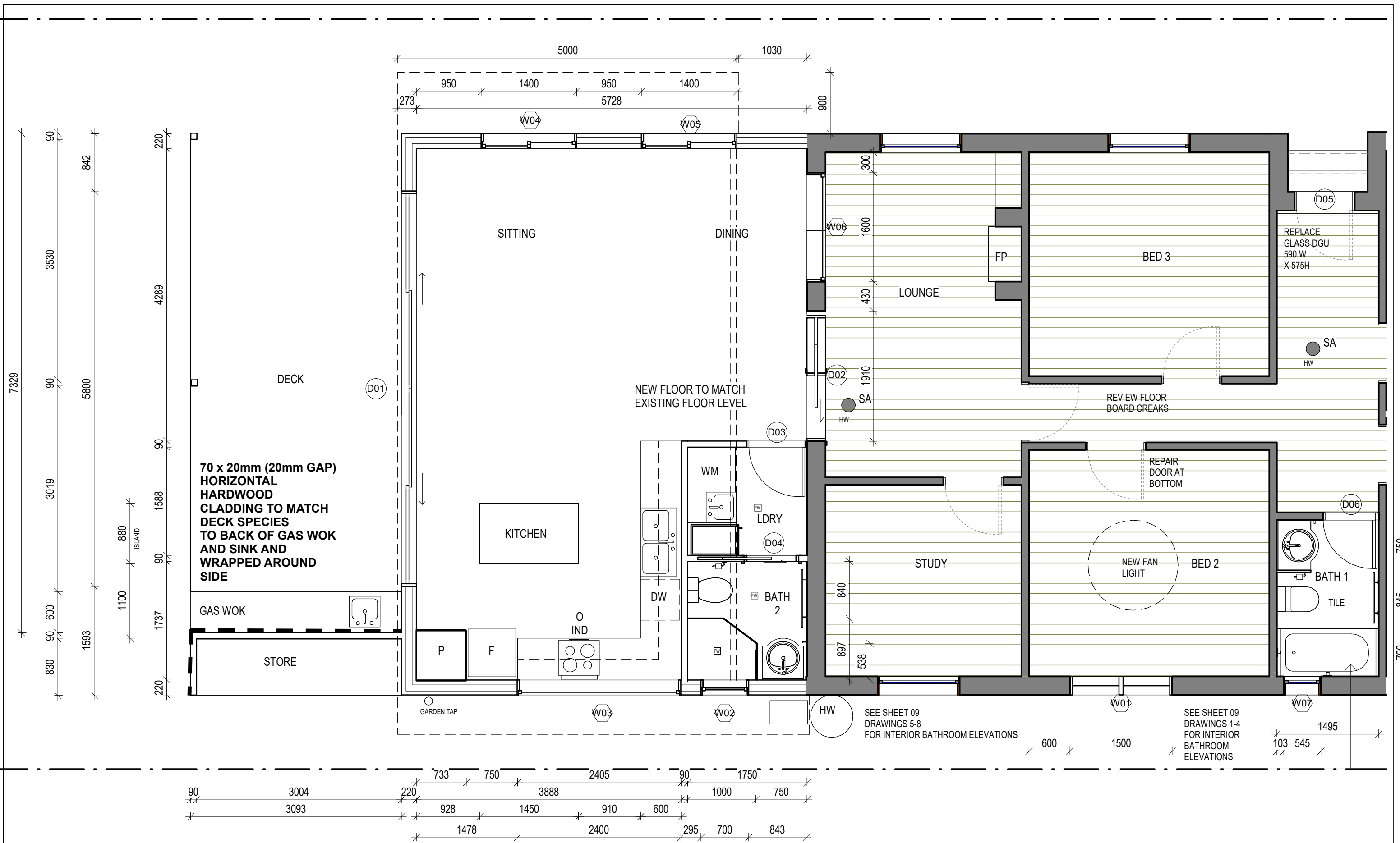

FOR CONSTRUCTION

TRACY GRAHAM
 12 PETERSHAM ROAD,
 MARRICKVILLE, NSW, 2204
 MOBILE 0405 4311119
 tracy@connecteddesign.com.au

Gwen and Richard Ng

70 Union Street Dulwich Hill

Proposed Floor Plan - Construction Details		
Project number	G03	04- B
Date	03/08/21	
Drawn by	CC	
Version	C01	
Scale @A3		1 : 50

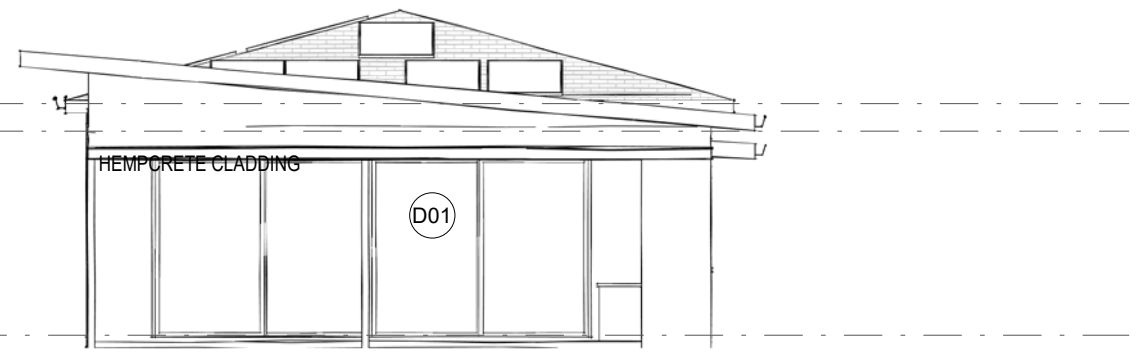
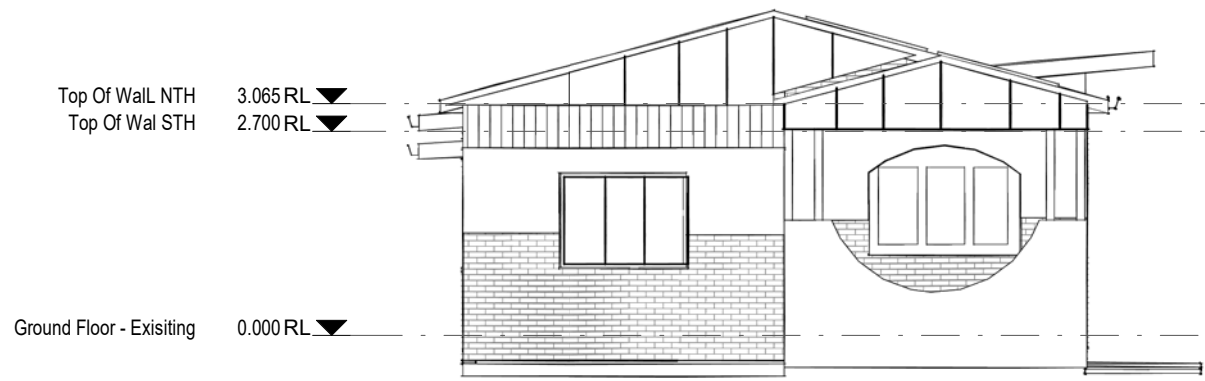

1 East Elevation. NO CHANGE TO EXISTING STREET SCAPE
1 : 100

2 West Elevation - Proposed
1 : 100

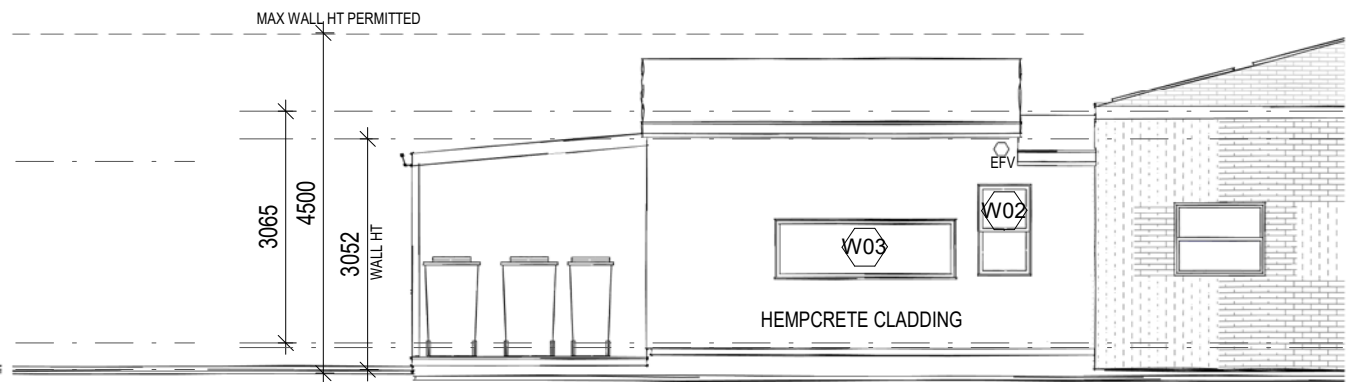
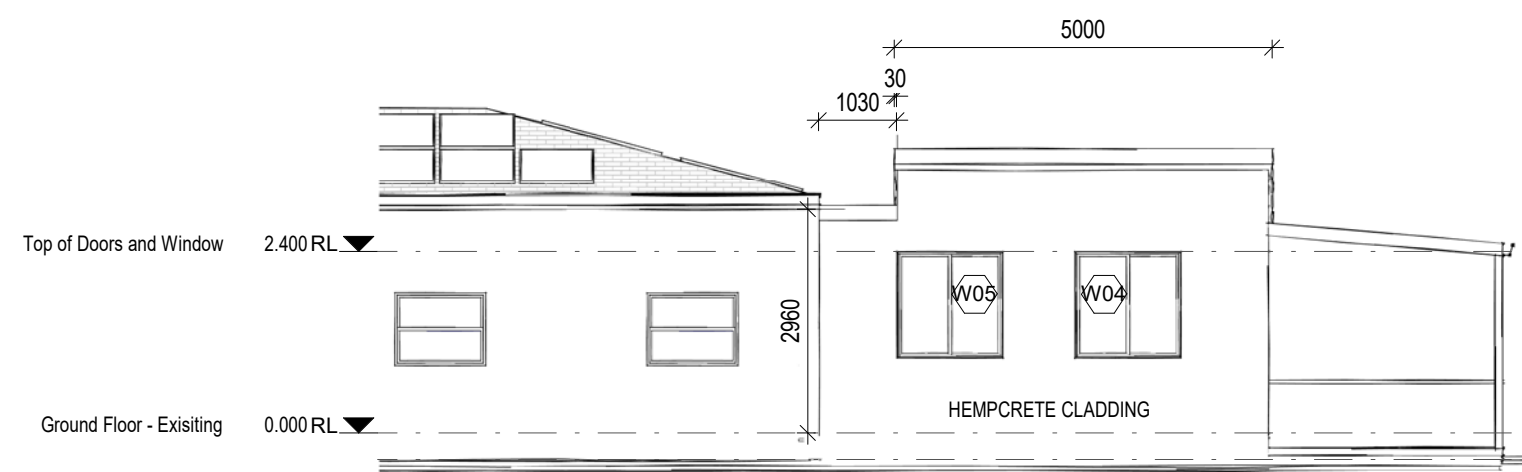

3 North Elevation - Proposed
1 : 100

4 South Elevation - Proposed
1 : 100

NOTE: PRIOR TO ANY CONSTRUCTION WORK COMMENCING

- ALL WORK MUST COMPLY WITH NCC
- CONFIRM ALL DIMENSIONS ON SITE PRIOR TO CONSTRUCTION
- ANY CONFLICTS MUST BE BROUGHT TO THE ATTENTION OF THE DESIGNER
- DO NOT MEASURE FROM THE PLANS

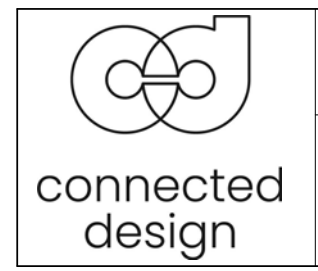

FOR CONSTRUCTION



TRACY GRAHAM
12 PETERSHAM ROAD,
MARRICKVILLE, NSW, 2204
MOBILE 0405 431119
tracy@connecteddesign.com.au

Gwen and Richard Ng

70 Union Street Dulwich Hill

Proposed Elevations

Project number	G03
Date	03/08/21
Drawn by	CC
Version	C01

05

Scale @A3 1 : 100

NOTE: PRIOR TO ANY CONSTRUCTION WORK COMMENCING

- ALL WORK MUST COMPLY WITH NCC
- CONFIRM ALL DIMENSIONS ON SITE PRIOR TO CONSTRUCTION
- ANY CONFLICTS MUST BE BROUGHT TO THE ATTENTION OF THE DESIGNER
- DO NOT MEASURE FROM THE PLANS

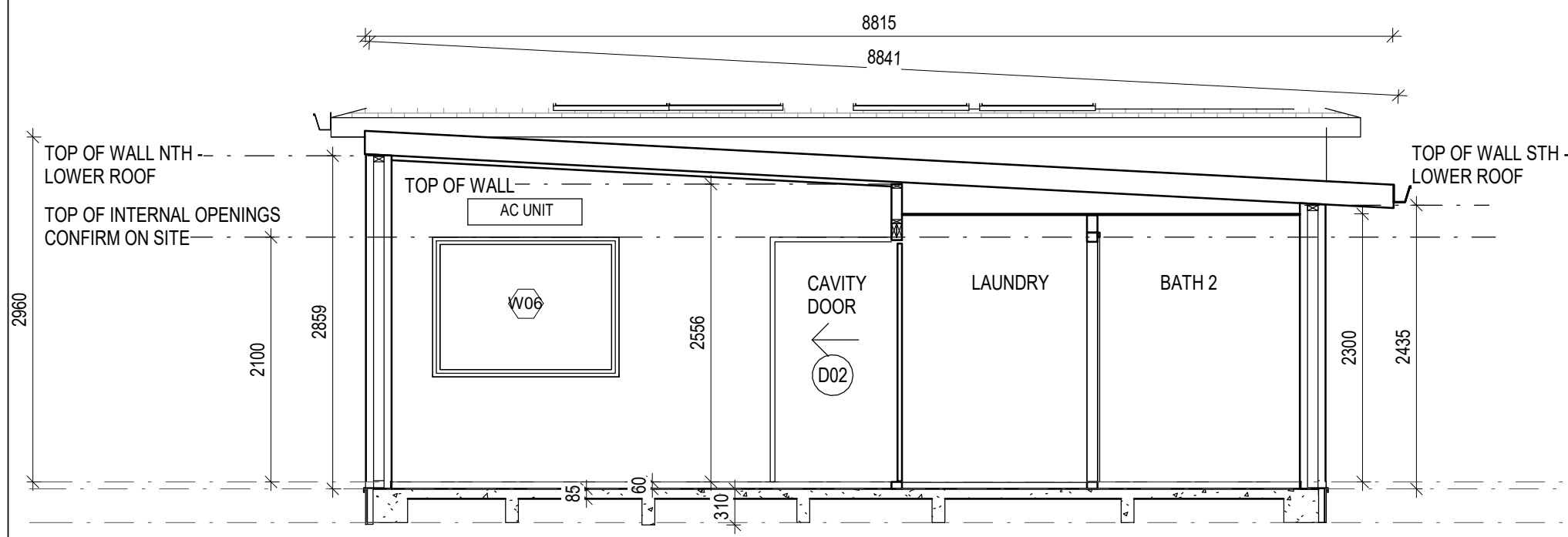

WAFFLE PAD TO ENGINEERS DETAIL

1 Section 1
1 : 50

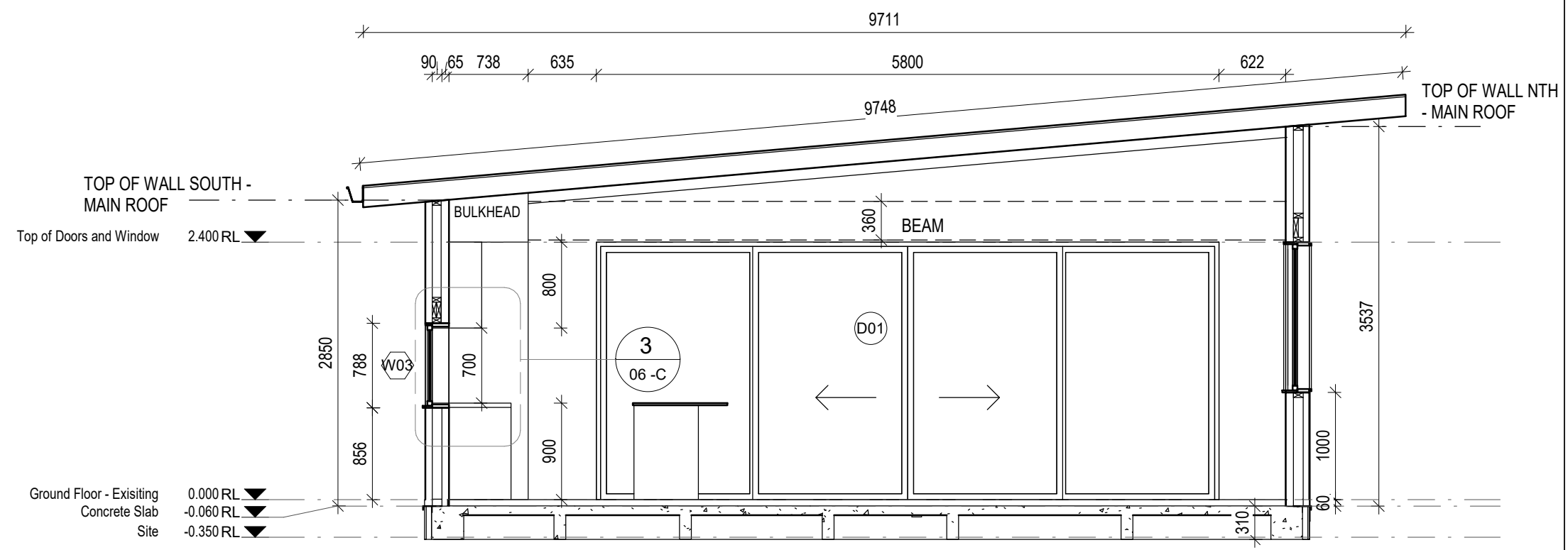

WAFFLE PAD TO ENGINEERS DETAIL

2 Section 2
1 : 50

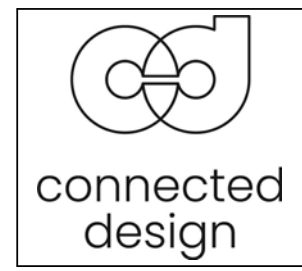

FOR CONSTRUCTION



TRACY GRAHAM
12 PETERSHAM ROAD,
MARRICKVILLE, NSW, 2204
MOBILE 0405 431119
tracy@connecteddesign.com.au

Gwen and Richard Ng

70 Union Street Dulwich Hill

Sections

Project number	G03
Date	03/08/21
Drawn by	CC
Version	C01

06 -A

Scale @A3 1 : 50

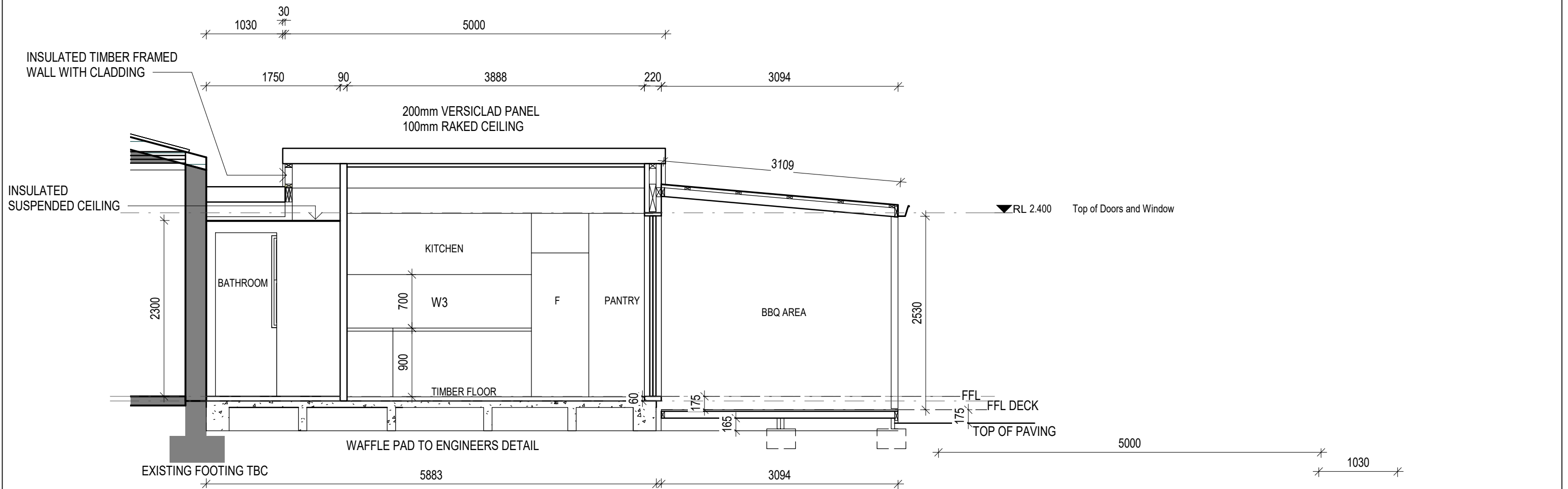

1 Section 3
1 : 50

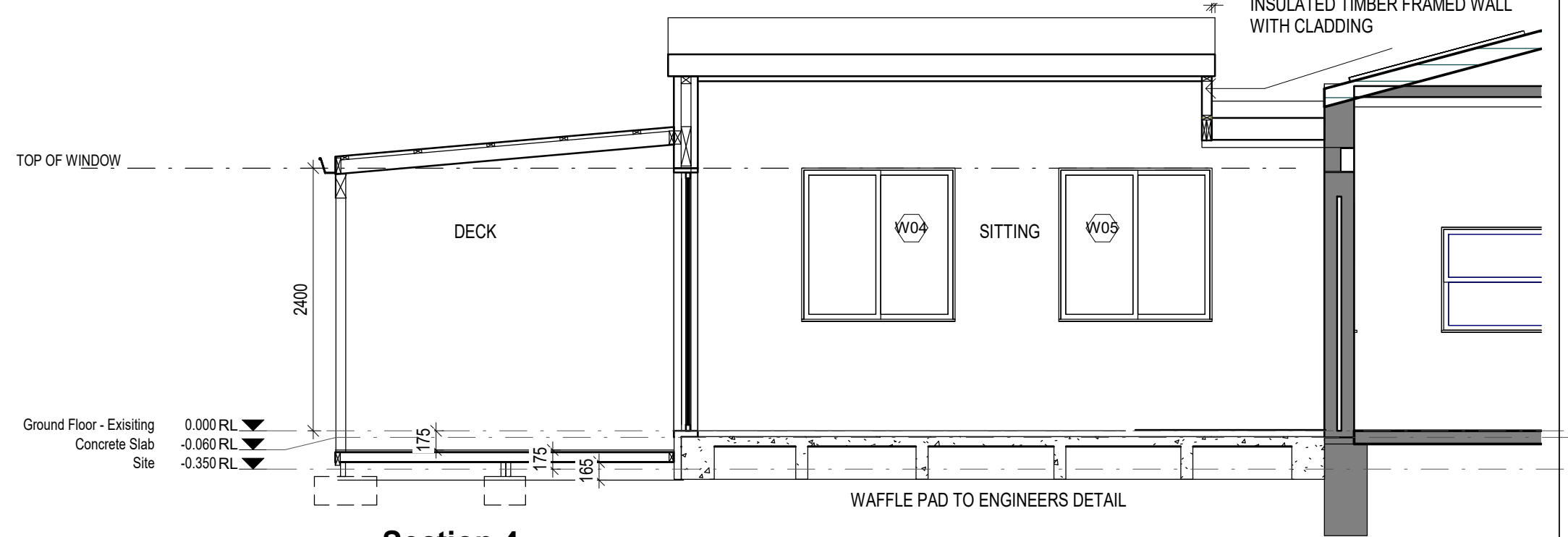

2 Section 4
1 : 50

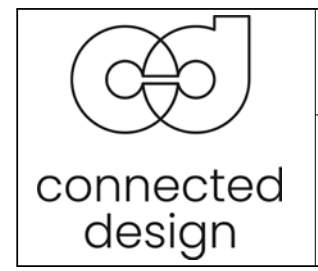

FOR CONSTRUCTION



TRACY GRAHAM
12 PETERSHAM ROAD,
MARRICKVILLE, NSW, 2204
MOBILE 0405 431119
tracy@connecteddesign.com.au

Gwen and Richard Ng

70 Union Street Dulwich Hill

Sections

Project number	G03
Date	03/08/21
Drawn by	CC
Version	C01

06 -B

Scale @A3 1 : 50

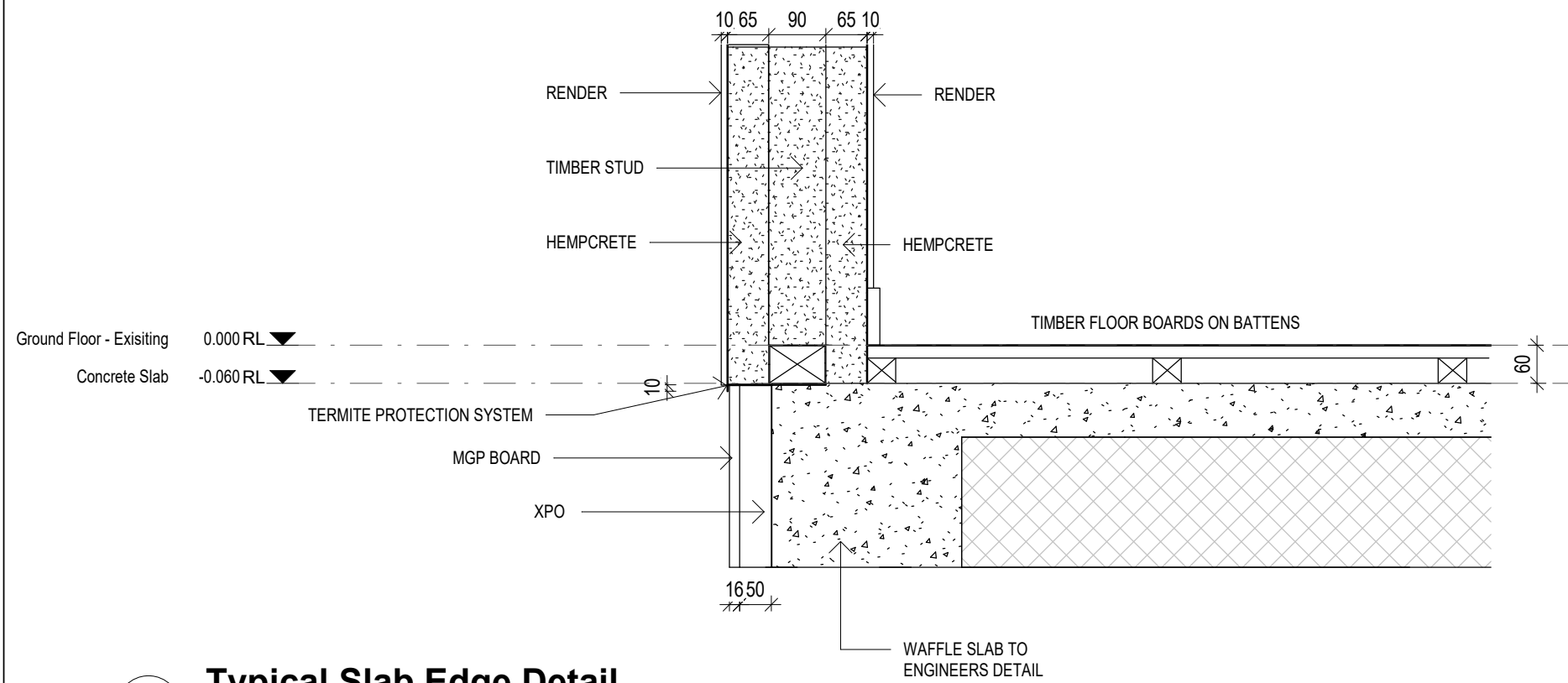

1 Typical Slab Edge Detail
1 : 10

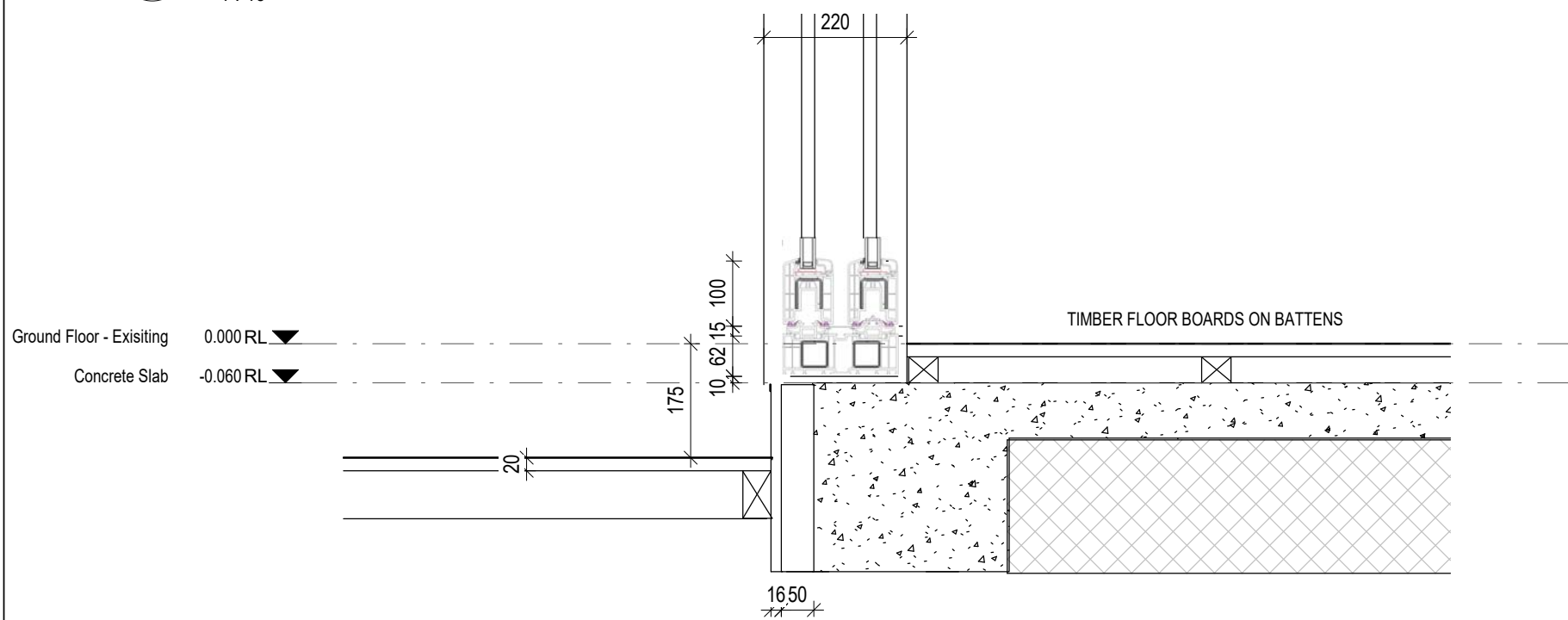

2 Sliding Door Sill Detail
1 : 10

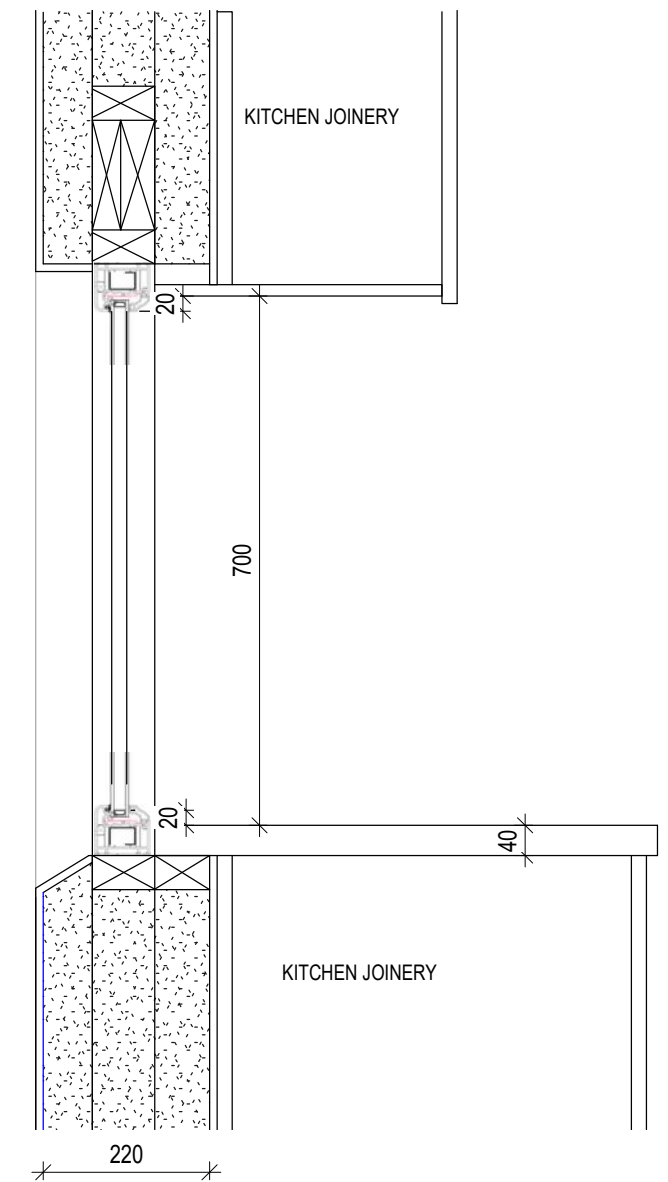

3 Kitchen Window Sill Detail
1 : 10

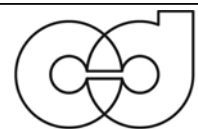

connected
design

FOR CONSTRUCTION



TRACY GRAHAM
12 PETERSHAM ROAD,
MARRICKVILLE, NSW, 2204
MOBILE 0405 431119
tracy@connecteddesign.com.au

Gwen and Richard Ng

70 Union Street Dulwich Hill

Detailed Sections

Project number	G03
Date	03/08/21
Drawn by	CC
Version	C01

06 -C

Scale @A3 1 : 10

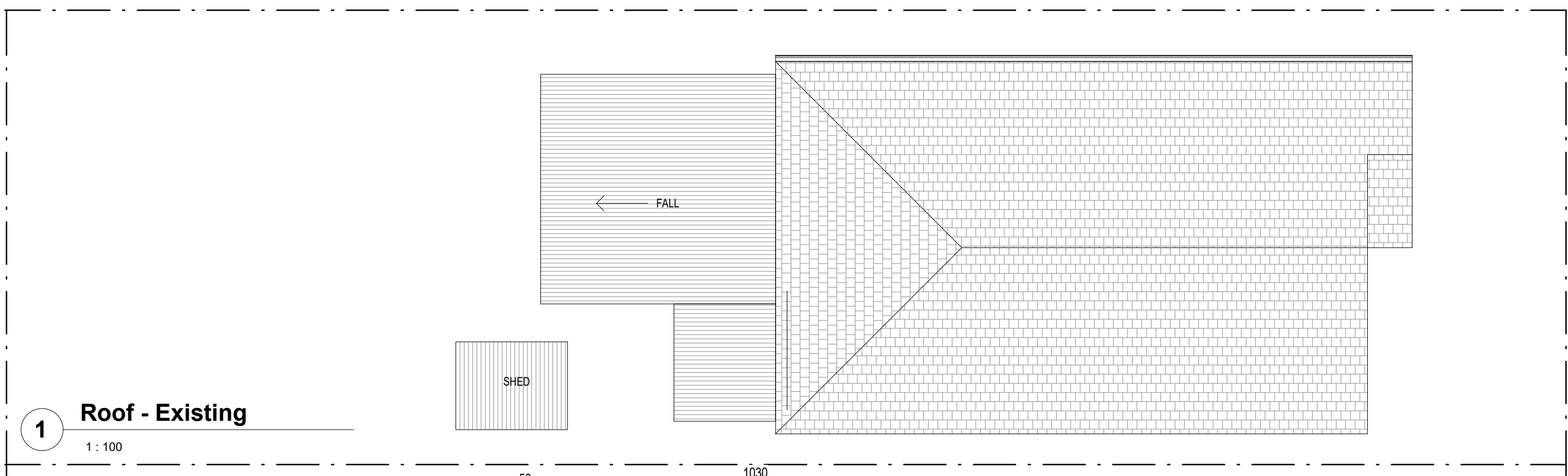

1 Roof - Existing
1 : 100

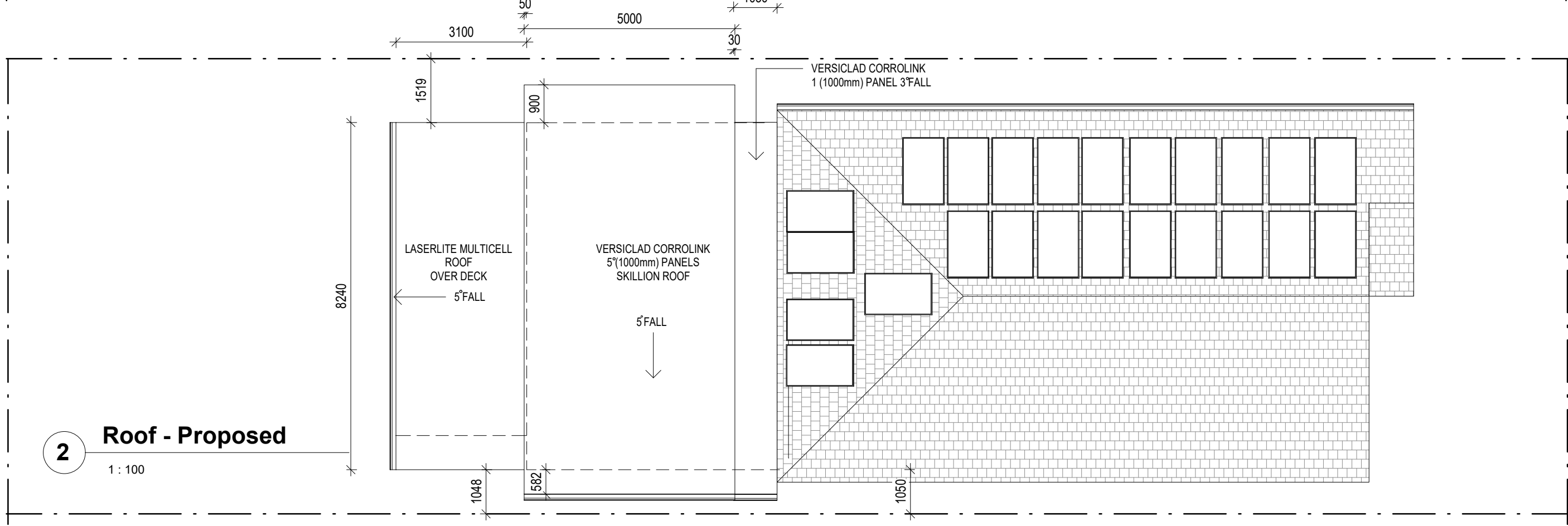

2 Roof - Proposed
1 : 100

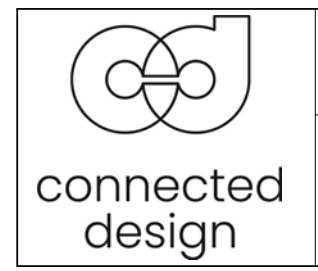

FOR CONSTRUCTION

bdqa
ACCREDITED
BUILDING DESIGNER

TRACY GRAHAM
12 PETERSHAM ROAD,
MARRICKVILLE, NSW, 2204
MOBILE 0405 431119
tracy@connecteddesign.com.au

Gwen and Richard Ng

70 Union Street Dulwich Hill

Roof Plan			07
Project number	G03		
Date	03/08/21		
Drawn by	CC		
Version	C01		Scale @A3 1 : 100

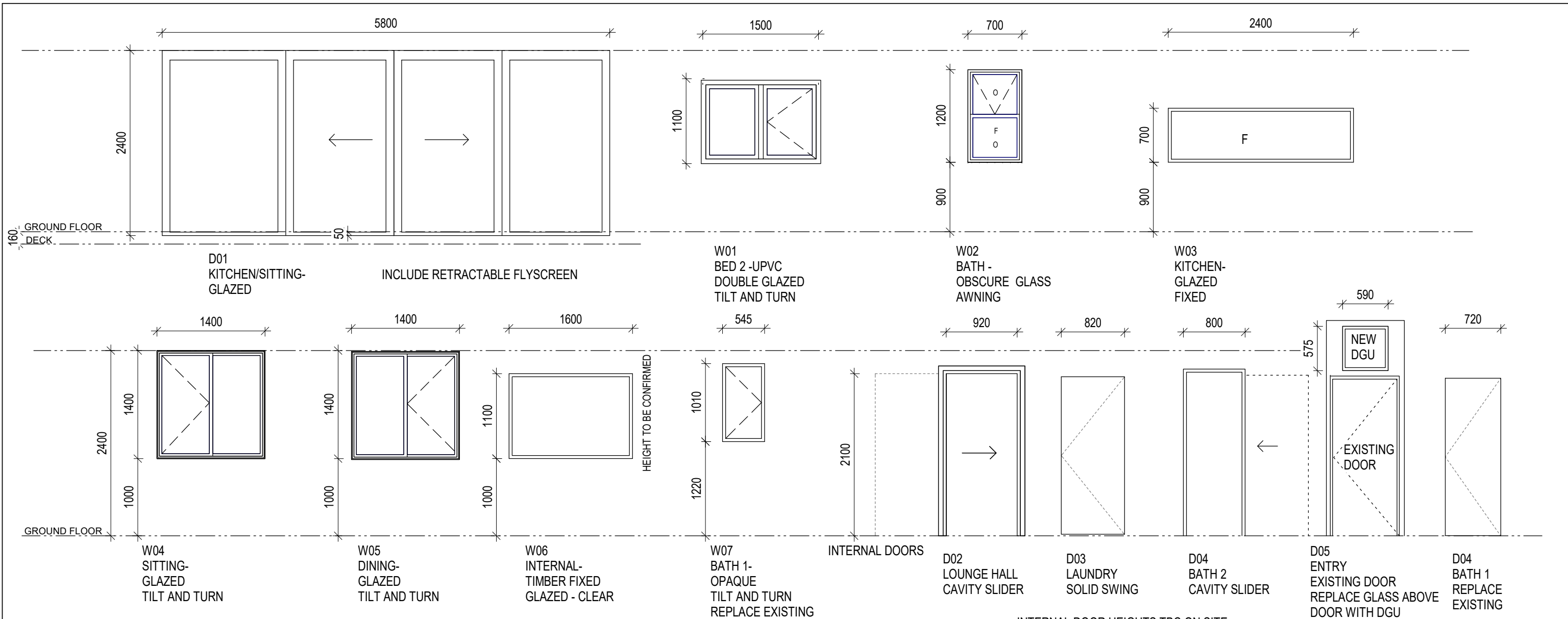

BASIX REQUIREMENTS - CERTIFICATE NO A411984 02

Windows and glazed doors glazing requirements

Window / door no.	Orientation	Area of glass inc. frame (m2)	Overshadowing		Shading device	Frame and glass type
			Height (m)	Distance (m)		
D01	W	13.9	0	0	eave/verandah/pergola/balcony >=900 mm	timber or uPVC, clear/air gap/clear, (U-value: 3.67, SHGC: 0.59)
W01	S	2	0	0	eave/verandah/pergola/balcony >=450 mm	timber or uPVC, clear/air gap/clear, (U-value: 3.67, SHGC: 0.59)
W02	S	0.8	0	0	eave/verandah/pergola/balcony >=450 mm	timber or uPVC, clear/air gap/clear, (U-value: 3.67, SHGC: 0.59)
W03	S	1.3	0	0	eave/verandah/pergola/balcony >=450 mm	timber or uPVC, clear/air gap/clear, (U-value: 3.67, SHGC: 0.59)
W04	N	2	1.4	4	eave/verandah/pergola/balcony >=450 mm	timber or uPVC, clear/air gap/clear, (U-value: 3.67, SHGC: 0.59)
W05	N	2	1.4	4	eave/verandah/pergola/balcony >=450 mm	timber or uPVC, clear/air gap/clear, (U-value: 3.67, SHGC: 0.59)

F = FIXED PANEL
O = OBSCURE GLASS

NOTE: All windows and external doors must include flyscreens

- NOTE: PRIOR TO ANY CONSTRUCTION WORK COMMENCING
- ALL WORK MUST COMPLY WITH NCC
 - CONFIRM ALL DIMENSIONS ON SITE PRIOR TO CONSTRUCTION
 - ANY CONFLICTS MUST BE BROUGHT TO THE ATTENTION OF THE DESIGNER
 - DO NOT MEASURE FROM THE PLANS

	FOR CONSTRUCTION	Gwen and Richard Ng	Door and Window Schedule												
		TRACY GRAHAM 12 PETERSHAM ROAD, MARRICKVILLE, NSW, 2204 MOBILE 0405 431119 tracy@connecteddesign.com.au	70 Union Street Dulwich Hill	<table border="1"> <tr> <td>Project number</td> <td>G03</td> <td rowspan="4">08</td> </tr> <tr> <td>Date</td> <td>03/08/21</td> </tr> <tr> <td>Drawn by</td> <td>CC</td> </tr> <tr> <td>Version</td> <td>C01</td> </tr> <tr> <td colspan="2">Scale @A3</td> <td>1 : 50</td> </tr> </table>	Project number	G03	08	Date	03/08/21	Drawn by	CC	Version	C01	Scale @A3	
Project number	G03	08													
Date	03/08/21														
Drawn by	CC														
Version	C01														
Scale @A3		1 : 50													

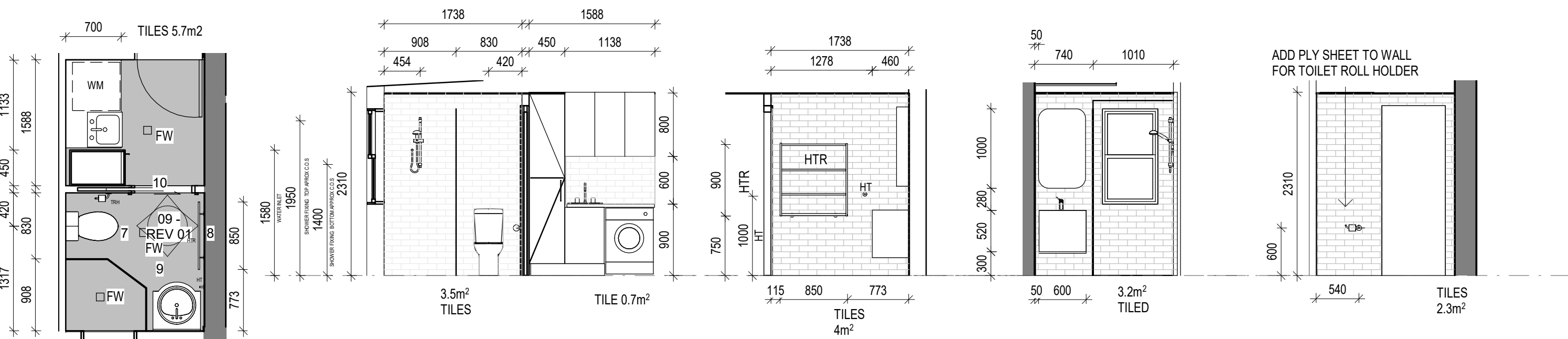
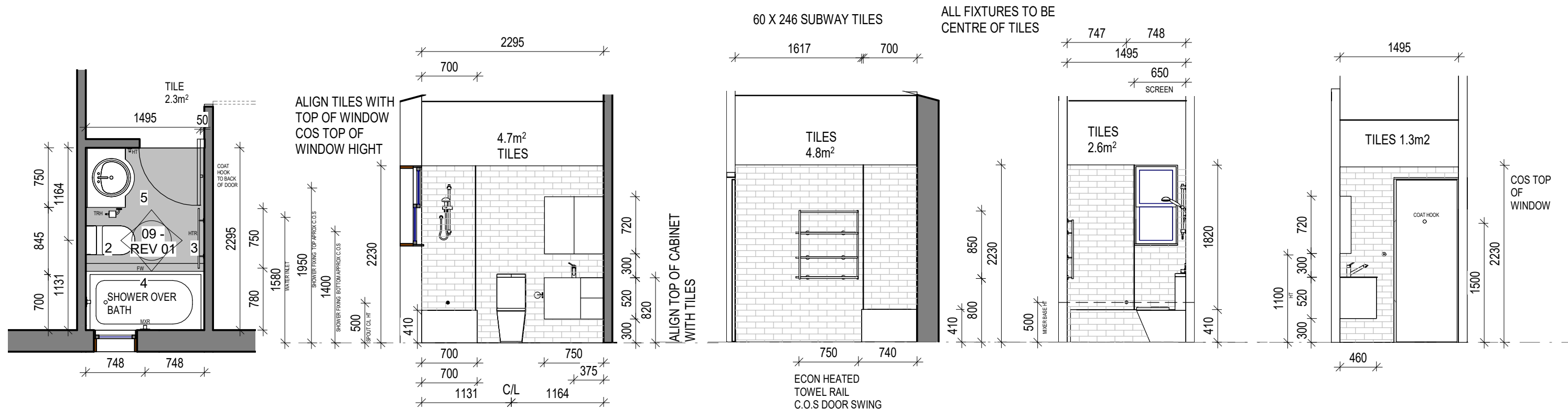

FOR CONSTRUCTION



TRACY GRAHAM
12 PETERSHAM ROAD,
MARRICKVILLE, NSW, 2204
MOBILE 0405 431119
tracy@connecteddesign.com.au

Gwen and Richard Ng

70 Union Street Dulwich Hill

Bathroom & Laundry Elevations

Project number	G03
Date	03/08/21
Drawn by	CC
Version	C01

09 - REV 01

Scale @A3 1:50

AC UNIT TO CONNECT TO EXISTING CONDENSER

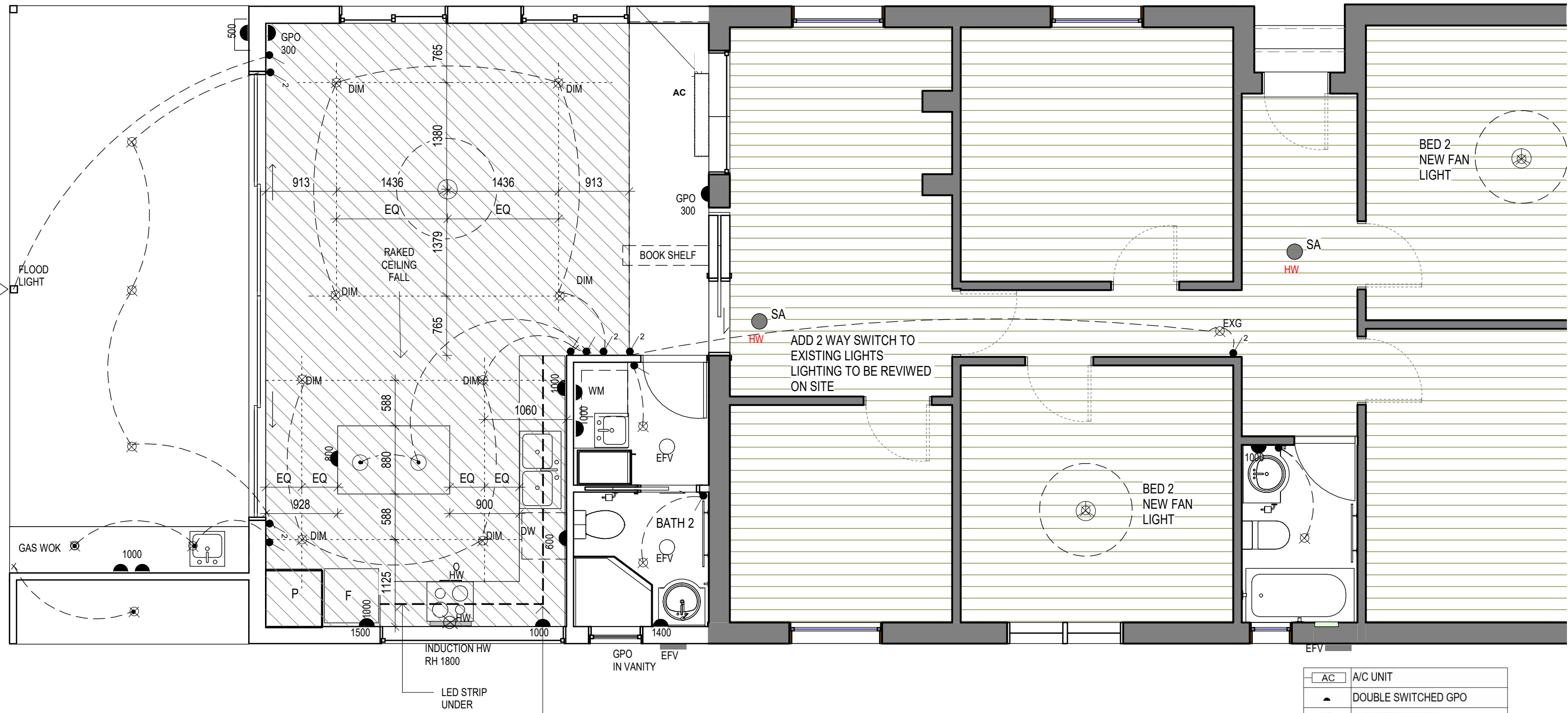

1 Ground Floor - Electrical Plan
1 : 50

Fixtures and systems	Show on DA Plans	Show on CC/CDC Plans & specs	Certifier Check
Hot water The applicant must install the following hot water system in the development: electric heat pump system that is eligible to create Renewable Energy Certificates under the (Commonwealth) Renewable Energy (Electricity) Regulations 2001 (incorporating Amendment Regulations 2005 (No. 2)).	✓	✓	✓
Lighting The applicant must ensure a minimum of 40% of new or altered light fixtures are fitted with fluorescent, compact fluorescent, or light-emitting-diode (LED) lamps.		✓	✓
Fixtures The applicant must ensure new or altered showerheads have a flow rate no greater than 9 litres per minute or a 3 star water rating. The applicant must ensure new or altered toilets have a flow rate no greater than 4 litres per average flush or a minimum 3 star water rating. The applicant must ensure new or altered taps have a flow rate no greater than 9 litres per minute or minimum 3 star water rating.		✓ ✓ ✓	✓ ✓ ✓

AC	A/C UNIT
●	DOUBLE SWITCHED GPO
⊗	LED DOWN LIGHT
●/2	TWO WAY SWITCH
●	ONE WAY SWITCH
○	PENDANT LIGHT
⊙	CEILING FAN
DIM	DIMMER SWITCH
HW (SA)	HARD WIRED SMOKE ALARM
EF	EXHAUST FAN WALL MOUNTED
EFV	EXHAUST FAN VENT
⊗	FLOOD LIGHT
▨	RAKED CEILING

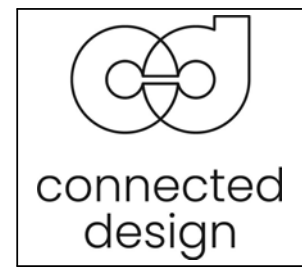

FOR CONSTRUCTION

bdca
ACCREDITED BUILDING DESIGNER

TRACY GRAHAM
12 PETERSHAM ROAD,
MARRICKVILLE, NSW, 2204
MOBILE 0405 431119
tracy@connecteddesign.com.au

Gwen and Richard Ng

70 Union Street Dulwich Hill

Electrical Plan		10	Scale @A3	1 : 50
Project number	G03			
Date	03/08/21			
Drawn by	CC			
Version	C01			