

Fellowes
AIR PURIFIERS

THE MOST
PREPARED SPACES
HAVE FELLOWES



We care deeply about helping you be at your best.

We want professionals to be the best they can be. More productive. More efficient. Happier. Healthier. That's why as a fourth-generation family business we're committed to creating quality business machines, storage products, workspace wellness solutions and air purifiers. Designed to meet—and exceed—the needs of an ever-changing world. Whether in a corporate facility or a home office, we'll help you be more productive so you can dominate the day. Because to be your very best, you need someone with experience in your corner. Fellowes Brands.

Fellowes
Brands™

FAMILY BUSINESS
SINCE 1917

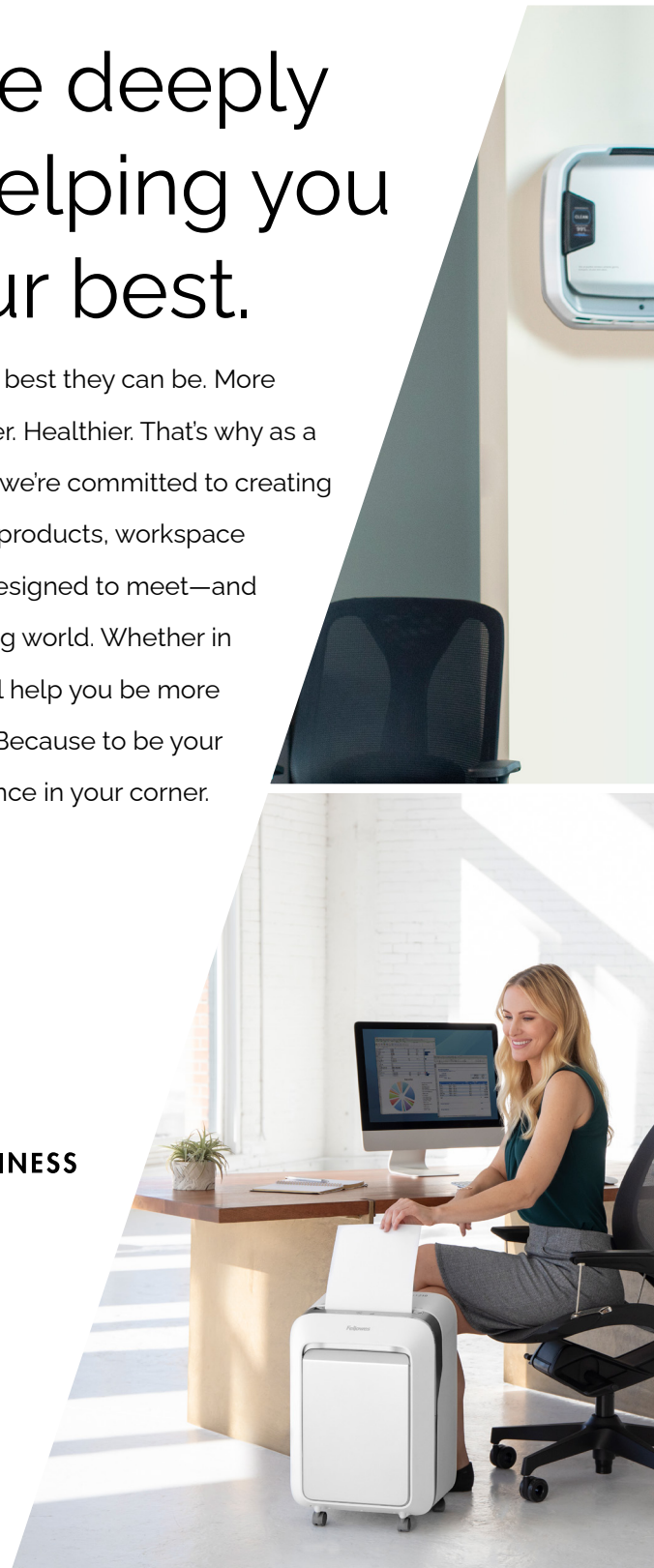

Fello

Fellowes

AIR PURIFIERS



THE AIRBORNE THREAT IS REAL

Reopening safely begins with responsible steps to protect ourselves and each other. COVID-19 spreads in the air when we speak, laugh, cough, and sneeze. Now more than ever, your protective efforts must include safeguarding what people breathe.



COVID-19 Is an airborne Threat

Experts agree: using air purifiers with true HEPA filtration reduces the threat of transmission



"The virus can remain suspended in the air for up to 3 hours"

New England Journal of Medicine

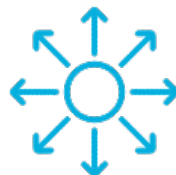

"Respiratory aerosols can accumulate indoors in rooms with low ventilation or poor filtration"

Lancet COVID-19 Commission, March 2021



"Portable HEPA air cleaners can reduce exposure to simulated SARS-CoV-2 aerosols in indoor environments"

CDC, July 2021

How People are Infected

Study after study proves viruses can be spread through air via two transmission methods.

- Airborne transmission via large droplets (> 10 microns) when people cough or sneeze (2m risk)
- Airborne transmission through small particles (<5 microns) also generated by coughing/sneezing/talking₂

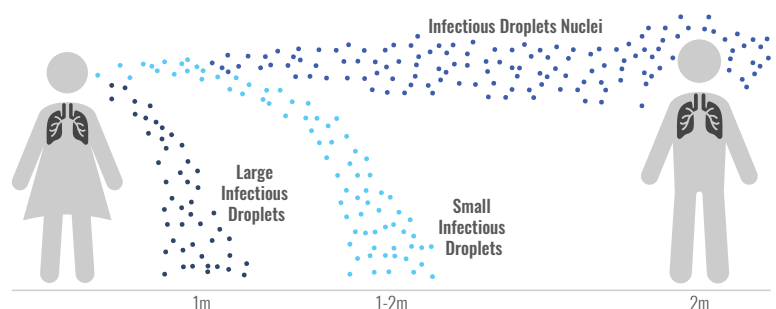

Sources:

- 1 https://wwwnc.cdc.gov/eid/article/26/7/20-0885_article
- 2 <https://www.nejm.org/doi/full/10.1056/NEJMc2004973>

REMOVES OVER 99.99% OF COVID-19†

In a recent test, Fellowes air purifiers demonstrated to eliminate COVID-19‡, using a combination of smart and integrated technologies—only from Fellowes.



The AeraMax Pro air purifiers were evaluated in extreme laboratory operating conditions, certainly much more critical and difficult than the real environmental situation. This situation was purposely designed since it is necessary to test the effectiveness of similar sanitizing devices in critical conditions to guarantee their effective performance. Despite the extreme conditions used, the Fellowes air purification technology was able to neutralize the airborne viral load.



Dr. Alberto Izzotti,

Department of Experimental Medicine at University of Genoa, School of Medicine, where the Fellowes test was conducted



This air purifier removes airborne germs, allergens, viruses and odors.

Fellowes continues to illustrate the effectiveness of the AeraMax Pro line of commercial air purifiers by utilising independent testing and third-party standards to prove our performance. Fellowes is committed to expanded testing with fully accredited and independent labs.

» [Go to our Research page for more details at Fellowes.com/air](https://www.fellowes.com/air)

†Fellowes AeraMax Pro air purifiers demonstrated, through independent laboratory testing, to be effective in eliminating aerosolized concentration of SARS-CoV-2 by 99.9999% through a single air pass test of the purifier. In addition, AeraMax Pro air purifiers reached 99.99% airborne reduction of a surrogate Human Coronavirus 229E in a 20m3 test chamber within 1 hour of operation in a separate test.

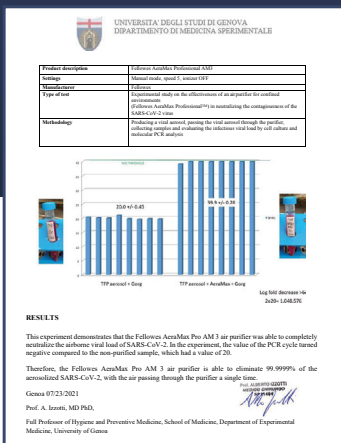

SARS-CoV-2

Fellowes air purifiers demonstrated, through independent laboratory testing, to be effective in eliminating aerosolized concentration of SARS-CoV-2 by 99.9999% through a single air pass test of the purifier.

Test Summary

The following products have been tested by Shanghai WEPU Chemical Technology Service Co., Ltd as outlined in report(s): WP-20118895-IC-021a; WP-20118895-IC-021b; WP-20118895-IC-021c; WP-20118895-IC-021d; WP-20118895-IC-021e; WP-20118895-IC-021f; WP-20118895-IC-021g.

Report ID	Product	With the Filter	Antimicrobial Activity Rate (%)
WP-20118895-IC-021a	AeraMax Pro AM2	Hybrid Filter	>99.99%
WP-20118895-IC-021b	AeraMax Pro AM3/5	Pre-Filter-Carbon/HEPA-H13A Filter	>99.99%
WP-20118895-IC-021c	AeraMax Pro AM3/5	Pre-Filter-Hybrid Filter	>99.99%
WP-20118895-IC-021d	AeraMax Pro AM3/5	Pre-Filter-Carbon/HEPA-H13A Filter	>99.99%
WP-20118895-IC-021e	AeraMax Pro AM3/5	Pre-Filter-Hybrid Filter	>99.99%

CORONAVIRUS

Fellowes AeraMax Pro air purifiers were demonstrated through independent laboratory testing to be effective in reducing aerosolized airborne concentrations of a surrogate Human Coronavirus 229E in a 20m3 test chamber within 1 hour of operation.



H1N1

The Fellowes AeraMax Pro AM3 and AM4 air purifiers have been shown to remove 99.99% of airborne virus within 35 minutes of operation.

PROTECT WHAT MATTERS



Your patients and visitors in **MEDICAL FACILITIES**

Poor air quality can lead to the airborne transmission of bacteria and viruses. In waiting rooms and consultation rooms in medical facilities the air must be cleaned in addition to surface and hand cleaning.



Your patients and employees in **DENTAL FACILITIES**

The dental profession is notorious for poor air quality, with labs brimming with dust from moulding and grinding appliances, and dental practices teeming with germs and bacteria from patient procedures. How bad is it? The dental profession has five of the top ten unhealthiest occupations, according to the U.S. Department of Labor.



Your residents and staff in **ELDERLY CARE FACILITIES**

The elderly are more vulnerable to viruses and other respiratory illnesses and have the added concern of weakened immune systems. There is also a high amount of visitors and an obvious need to protect the workforce from potential airborne threats.



Your employees in **CORPORATE OFFICES**

Office buildings are a prime example of a space that we share for upwards of 9 hours every day and have a constant flow of visitors, vendors and employees who bring viruses, germs and pathogens into the workplace with them. Couple that with odours from food left in waste bins, conference rooms and common areas and it's an IAQ hot spot.



Your students and staff in **CLASSROOMS AND DAYCARE FACILITIES**

Common areas and classrooms are breeding grounds for germs—and young respiratory systems are more susceptible to irritants that can exacerbate childhood allergies and asthma. What's more, facilities staff find it increasingly difficult to effectively clean high-traffic areas rife with bacteria and viruses.



Your customers, guests and staff in **HOSPITALITY, BEAUTY AND FITNESS FACILITIES**

Busy shared air environments where we spend our free time and our money, can be high risk for transmission. Improved indoor air quality is a great way to provide maximum peace of mind for customers and improve brand perception. Hygiene and sanitation is essential in these environments.

WHY AERAMAX PRO





EFFECTIVE
Proven Performance

SMART
Patented, Responsive
Technology

INTEGRATED
A Seamless Addition

RELIABLE
Commercial Grade Durability

EFFECTIVE

Proven Performance

The AeraMax Pro four-stage filtration process uses the following proven methods to effectively clean the air

1

The **pre-filter** captures large particles and contaminants and helps protect the lifespan of other filters

2

Active Carbon filtration adsorbs odours and VOCs from the air

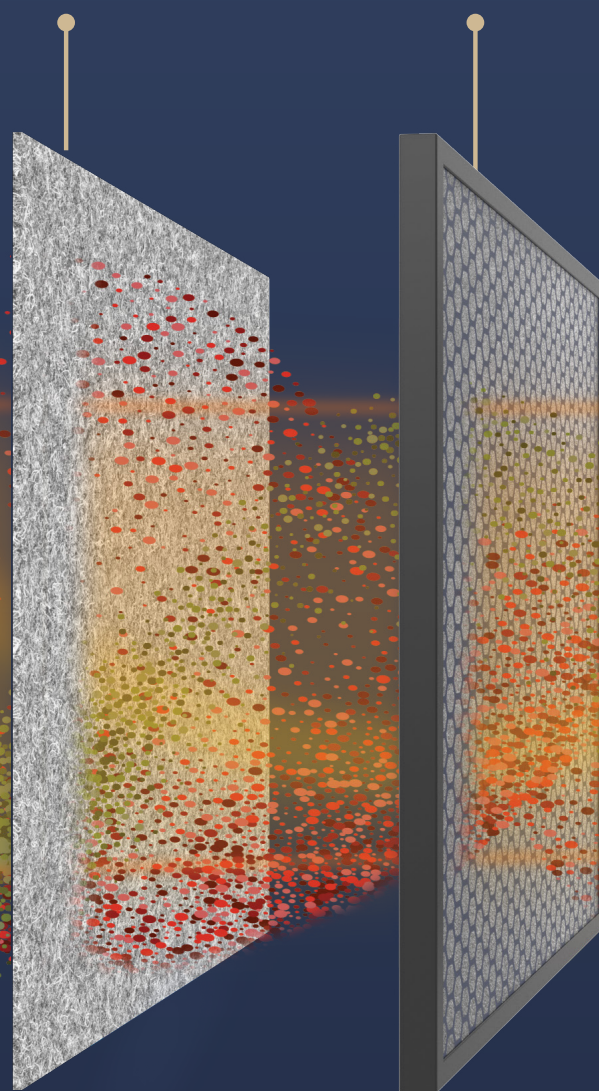

3

The **H13 HEPA filter** (AM3 and AM4) captures up to **99.95%** of particles as small as 0.1 microns.

AeraSafe™ antimicrobial treatment applied to the H13 HEPA filter inhibits the growth of odour and stain-causing microorganisms, extending the filter lifespan.

4

The **PlasmaTrue™ Bipolar Ioniser** improves the capture efficiency of the particulate filter

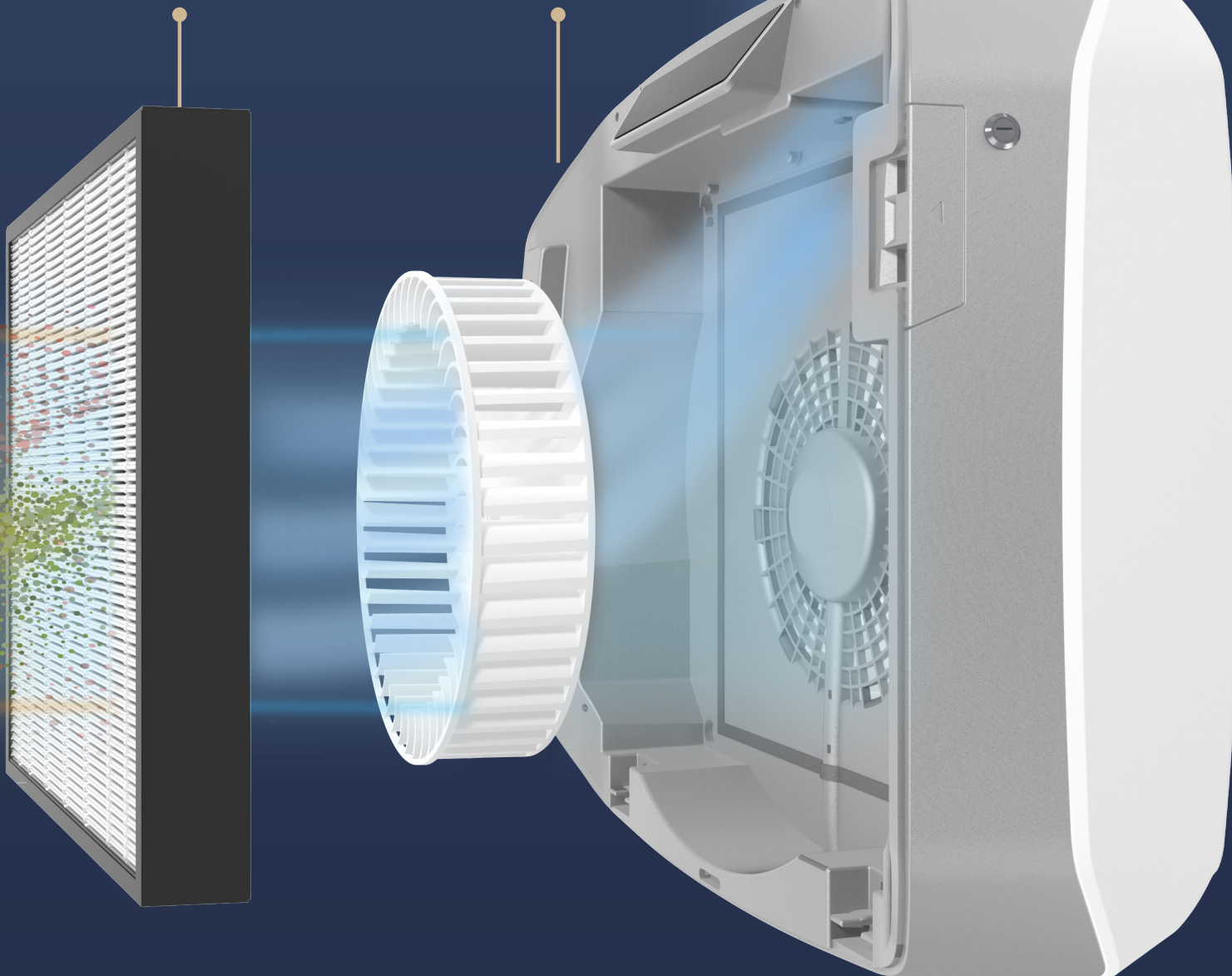

SMART

Patented, Responsive Technology



Patented EnviroSmart™ Technology uses dual self-regulating laser sensors to measure sound, motion and air quality

This technology means that AeraMax Pro works hard when it needs to, and shifts to standby when possible, saving energy and extending filter lifespan.

There are two sensing modes:

- 🔊 Normal Mode: automatically adjusts between all fan speeds to control air quality (ideal for most shared spaces)
- 🔊 Quiet Mode: uses quieter fan speeds when the space is occupied and all fan speeds when space is unoccupied (ideal where noise could be a concern)



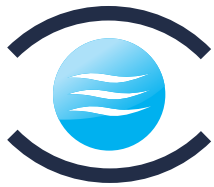

PureView™

Seeing is believing - the best way to show your facility occupants that you are taking their health seriously is to show them! The invisible becomes visible with PureView™ technology, a display that allows occupants to see the difference as they feel the difference.

Two high grade laser particle counters monitor air quality as it enters and exists the machine, enabling the screen to show the air quality data in two different display modes:

- Room Status: shows the current air quality in the room and the % of particles being captured in real-time.
- PM2.5: Displays real time the PM2.5 levels entering the unit and being removed in the filtration process.

The screen also showcases VOC/Odour levels and filter change reminders.

Maximum peace of mind for your facility users and **maximum visibility** for your facilities team.



This air purifier removes airborne allergens, viruses and odors.

INTEGRATED

A Seamless Addition

The AeraMax Pro was designed to seamlessly integrate into your facility's environment. All models are wall-mountable, unobtrusive and aesthetically pleasing, so you can provide worry-free air purification wherever it's needed most.



RELIABLE

Commercial Grade Durability

All AeraMax Pro units are built with 24/7/365 operation in mind. That means continual use...and that means they're constructed with superior components, high-grade filters and reinforced housings.

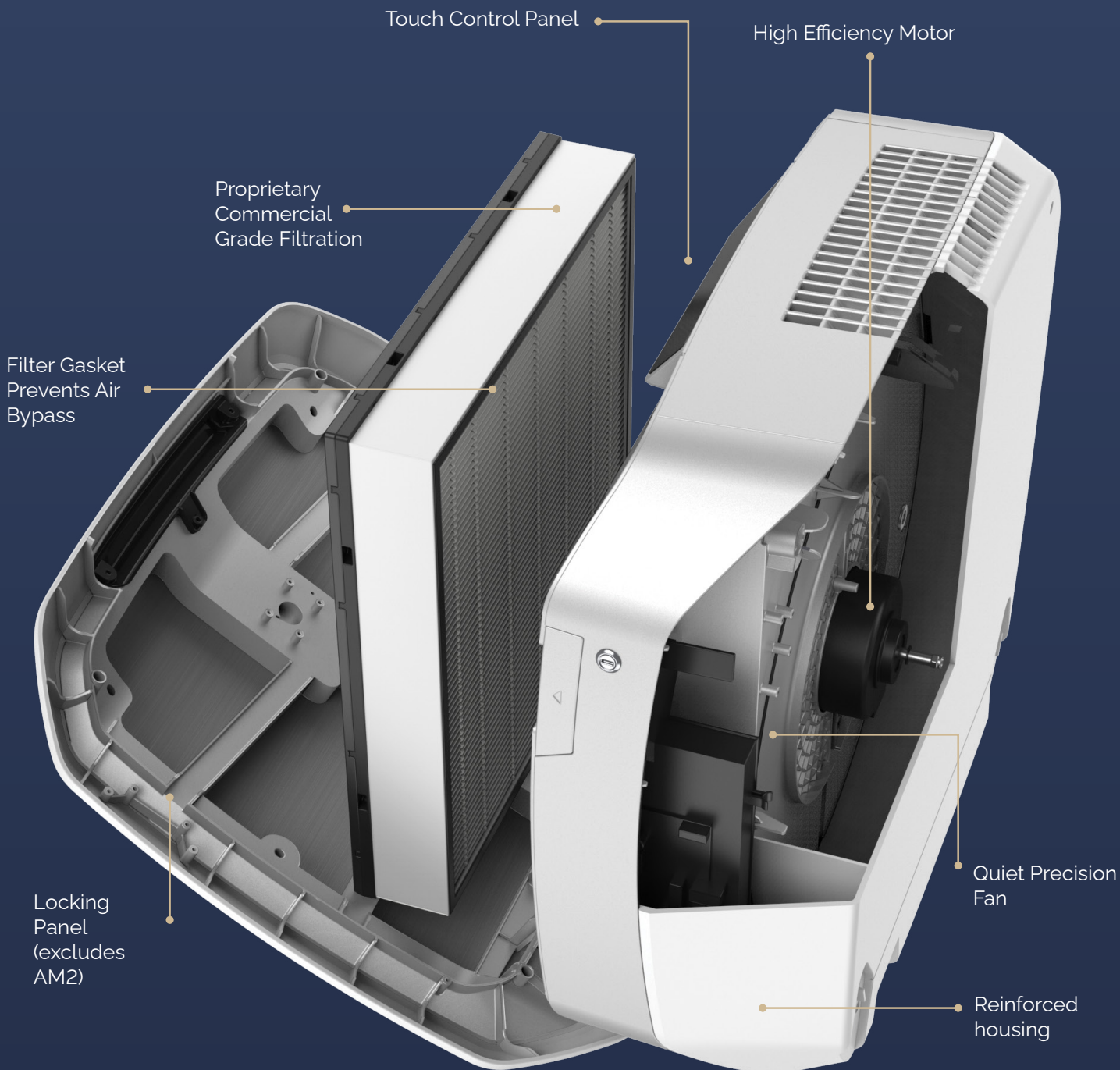

AM 3 & 4 = 5 year warranty

AM 2 = 3 year warranty

THE AERAMAX PRO DIFFERENCE

It Starts With Great HEPA Filtration

A well-engineered machine is quickly let down if using poor filters. Our AeraMax Pro units with H13 HEPA filters capture at least 99.95% of particles as small as 0.1 microns, including allergens, such as pollen, dust, pet dander, and smoke.

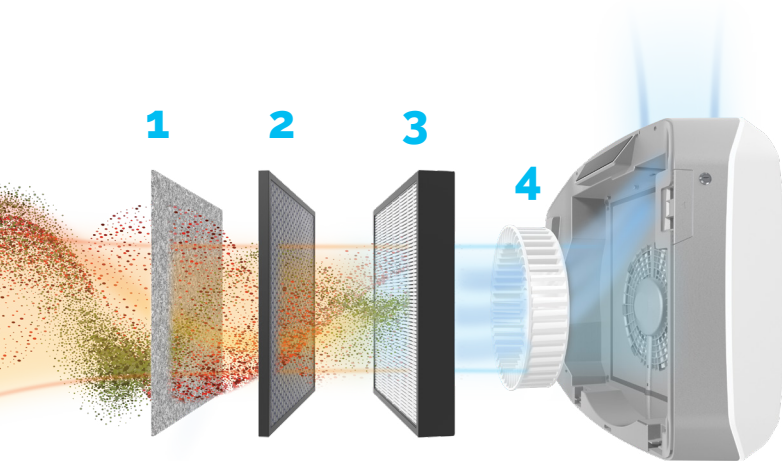

The four stage filtration process:

1. **Pre-Filter** captures large particles
2. **Active Carbon** filtration adsorbs odours and VOCs from the air
3. **H13 HEPA filter** captures up to 99.95% of particles as small as 0.1 microns
4. **PlasmaTrue™ Bipolar Ioniser** improves the capture efficiency of the particulate filter

Localised Air Purification Benefits Beyond COVID-19

Indoor Air is
2-5x
DIRTIER
than Outdoor Air



Bacteria



Allergens &
Asthma Triggers



Odours



Pollution &
Volatile Organic
Compounds (VOCs)

The Experts Agree

CDC: Use portable high-efficiency particulate air (HEPA) fan/filtration systems to enhance air cleaning" —CDC 6.2.21

<https://www.cdc.gov/coronavirus/2019-ncov/community/ventilation.html>



CIBSE: "Room air cleaners effectively remove particles from air which provides a similar effect compared to ventilation. To be effective, air cleaners need to have at least HEPA filter efficiency and to have a substantial part of room air pass through them"



Source: CIBSE COVID-19 Ventilation Guidance (Version 2, 12 May 2020)

THE SCIENCE OF CLEAN AIR

Computational Fluid Dynamics (CFD) Study

We conducted a comprehensive Computational Fluid Dynamics (CFD) simulation in an average, six-stall women's restroom. The study scenario included six toilets flushing at once, continuously with all stall doors closed.

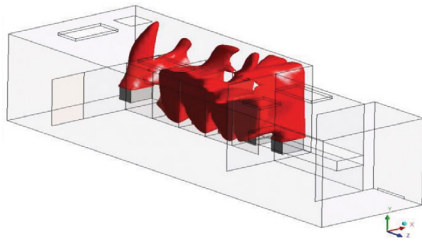

Contaminant Cloud Without System

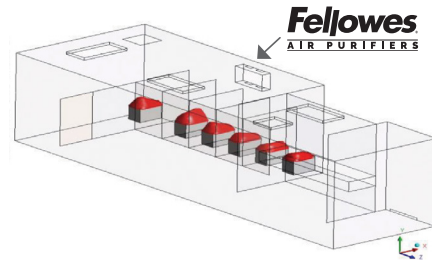

Contaminant Cloud With System Over Stalls

- **Significant decrease in concentration of contaminant at 2.5 PPM (red)**
- **Increase in pure air in area directly in front of stalls**
- **To achieve this with HVAC would require 250% flow rate increase**

Wall Mount Benefits



During our CFD simulation testing we observed significant full room filtration efficiency when wall mounted.

- Solution can be installed closer to the source concern
- Creates whole-room circulation and increases clean air distribution (less obstacles in air path)
- Contaminated air is pulled closer to head height (breathing level) and not from the floor
- Improves efficiency of ACH performance

How Is ACH Calculated

ACH is the amount of times we can move the volume of air in a room through our machine. It might seem complex, but the calculation is simply

$$\text{ACH} = \frac{\text{Volume of Air Flow Per Minute}}{\text{Cubic Feet of the Area}}$$

Air Changes Per Hour

AeraMax Professional room size recommendations are based on delivering

3-5 ACH

An ACH of 5 means your air is being cleaned every

12
Minutes

TESTIMONIALS

Delivering A Great Guest Experience

Legoland Discovery Center

Kid-centric LEGOLAND® Discovery Center's restrooms are visited by hundreds or thousands of visitors every day. Keeping them clean is challenging. Air fresheners only mask bathroom odour and do nothing to prevent the airborne germs that accompany them. For a truly clean facility, LEGOLAND® installed AeraMax Pro air purifiers in each of its facility's restrooms, resulting in a significant improvement in key performance indicators (KPI) for facility cleanliness.

“Clean air helped me deliver a CLEANER facility.”

Nick Miller, General Manager



Setting Students Up for Success with Clean Air

Culver Academies

The installation of the Fellowes air purifiers provided a permanent solution to air quality issues. In the military academy's boys' barracks, the older HVAC system was built under different requirements and was unable to handle the air changes per hour (ACH) required to keep the air clean. That's important since viruses and germs tend to linger in the air. So, the installation of Fellowes air purifiers significantly boosted the ACH in the enclosed spaces. They also provided hands-free operation by way of exclusive PureView Technology. Because each unit has a large digital display, students and staff could see the cleaning progress, which allayed any fears.

“Our teachers, students and administrators can see the air being cleaned, which provides a feeling of safety.”

Michael Squires, Commandant of Cadets

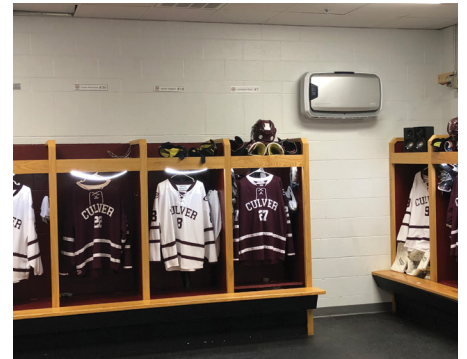

Little Lungs Need AeraMax Pro

Tiny Sprouts Early Childhood Center

Catering to 60 children every day, Tiny Sprouts Early Childhood Center had a significant germ and odour problem that was unsolved by traditional cleaning methods. So, Director Emily Sousa installed AeraMax Pro units throughout the school. The impact was immediate. And dramatic. "We've seen a significant difference in air quality," Sousa says. "In the morning, the room smells fresh and there's a complete difference in the way it feels." What's more, the new air purification routine paid additional dividends. Parents from other schools switched their children to Tiny Sprouts specifically because of its stance on cleanliness, health and safety, as well as the installation of the AeraMax Pro units.

"We were able to solve on-going problems with odour and germs."

Emily Sousa, Owner and Director



Tackling Aged Care Infection Control

Finley Regional Care (Aged Care)

Infection control was a worry for Finley Regional Care, where elder residents were more susceptible to flu and germs. Ben Levesque, CEO, is well aware of the role that Aged Care facilities play in providing high-level healthcare and quality of living to match the modern demands of the residents and their family members. That's why he had AeraMax Professional units installed. A turnkey solution to improving indoor air quality. A facility-wide roll out of AeraMax Professional purifiers in strategically positioned high-traffic shared living zones - including living areas, dining areas and around pan rooms. Not only does it demonstrate an unrivaled level of resident care against viruses and odours commonly associated with Aged Care facilities, but it also importantly addresses key accreditation standards. LittleStar was able to specify the exact type of Fellowes air purifier that was ideal for the space in need of cleaner, fresher air.

"If you're serious about infection control and improving your air quality, I'd definitely recommend these units."

Ben Levesque, Chief Executive Officer



THE LINEUP

Commercial
Air Purifiers

Removes over
99.99% of Covid-19†



AeraMax Pro AM4

The right size for large spaces

The AeraMax Pro AM4 is the largest of our commercial grade air purification systems and will deliver an air change every 20 minutes in rooms up to 110m². Multiple units can be used for larger spaces making it the ideal solution for open office layouts, large conference rooms and many large shared air spaces.

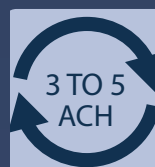

AeraMax Pro AM2

Small. But big.

The super slim design of the AeraMax Pro AM2 makes it the perfect fit for smaller spaces, offering 3-5 air changes per hour in shared indoor spaces between 15 and 25m². It's ideal for smaller examination rooms, narrow hallways and small public restrooms.

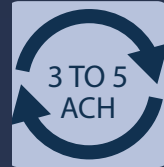

AeraMax Pro AM3

The perfect fit for most rooms

Our AeraMax Pro AM3 is perfect for most rooms, providing up to 3 air changes every hour in rooms as large as 55m². It's ideal for offices, conference rooms, classrooms, restrooms, waiting rooms and enclosed shared spaces.

SPECIFICATIONS



AeraMax Pro AM2



AeraMax Pro AM3 PC



AeraMax Pro AM4 PC

Smart Technology	EnviroSmart Technology	PureView Technology EnviroSmart Technology	PureView Technology EnviroSmart Technology
Area Coverage	15m ² (5 ACH) 25m ² (3 ACH)	30m ² (5 ACH) 55m ² (3 ACH)	65m ² (5 ACH) 110m ² (3 ACH)
No. of Fan Speeds	5	5	5
Airflow (m ³ /hour)	60, 73, 87, 109, 170	129, 158, 190, 238, 374	260, 316, 381, 476, 748
Sound Pressure Levels (dB)	38,42,51,60,66	42,47, 51, 58, 66	42, 47, 52, 58, 69
System Dimensions (HxWxD)	574 x 360 x 104mm	495 x 534 x 241mm	483 x 883 x 241mm
System Weight	5.8kg	9.1kg	15.9kg
Power Consumption (W)	7, 10, 14, 40, 70	5, 8, 11, 21, 100	8, 12, 18, 35, 166
Energy Star Certified	Yes	Yes	Yes
Power Requirements	220-240v, 50/60Hz, 2A	220-240V, 50/60Hz, 0.9A	220-240V, 50/60Hz, 1.4A
Electical Safety Certification	TUV, GS, CE	TUV, GS, CE	TUV, GS, CE
Air Intake / Outlet	Sides / Top	Bottom / Top	Bottom / Top
Control Panel	Capacitive Touch	Capacitive Touch & TFT LCD PureView Screen	Capacitive Touch & TFT LCD PureView Screen
Housing Material	UV Stabilised ABS	UV Stabilised ABS	UV Stabilised ABS
Operating Temperature	10°C-40°C	5°C-40°C	5°C-40°C
Operating Humidity	Up to 60% RH	Up to 60% RH	Up to 60% RH
Warranty	3 Year Limited	5 Year Limited	5 Year Limited

CONFIGURATIONS

Wall Mount			
Installation Method	Wall mouted with plug	Wall mounted hard wired	Wall mounted hard wired
Model Name Item code	AM2 5999501	AM3 PC 9573801	AM4 PC 9573901
Floor Stand			
Installation Method	Floor Stand Accessory 9540901	AU Plug Type	AU Plug Type
Model Name Item code	Recess Kit Accessory (Hard Wired Install) 9540802	AM3S PC 5999301	AM4S PC 5999401

FILTER SOLUTIONS

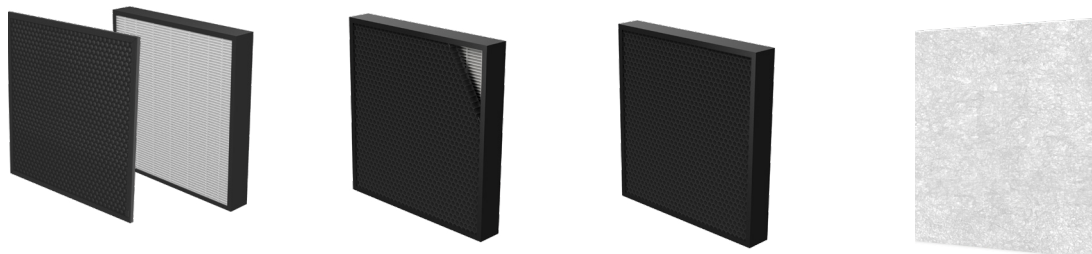

Filters for AeraMax Pro AM3 & 4 Models	Standard Filter Configuration	Hybrid Filter	Full Carbon Filter (High Odour/VOC)	Pre-Filters
Filter Type	10mm Carbon Filter (w/pre-filter) 50mm H13 HEPA	60mm filter containing 50% Carbon & 50% True HEPA	60mm Carbon Filter (w/pre filter)	Replacement Pre-Filter
HEPA Filter Media	2.5m ²	1.3m ²	NA	NA
Antimicrobial Treatment	Yes (H13 HEPA)	Yes (True HEPA)	No	No
Active Carbon Weight	0.45kg	1.8kg	2.7kg	NA
Estimated Filter Life	Carbon: 6 Months H13 HEPA: 12 Months	12 Months	12 Months	6-12 Months
Pack Size	Carbon: 4 Pack H13 HEPA: 2 Pack	2 Pack (ships with pre-filters)	2 Pack	4 Pack
Item Numbers	Carbon: 9416502 H13 HEPA: 9416602	9436902	9436802	9600501



Filters for AeraMax Pro AM2 Model	Standard Filter Configuration	True HEPA Filter	Full Carbon Filter (High Odour/VOC)	Pre-Filters
Filter Type	45mm filter containing 50% Carbon & 50% True HEPA	45mm True HEPA filter	45mm Carbon Filter	Replacement Pre-Filter
HEPA Filter Media	0.5m ²	1.1m ²	NA	NA
Antimicrobial Treatment	Yes (True HEPA)	Yes	No	No
Active Carbon Weight	340g	NA	680g	NA
Estimated Filter Life	12 Months	12 Months	12 Months	6-12 Months
Pack Size	1 Pack	1 Pack	1 Pack	4 Pack
Item Numbers	9544501	9544301	9544601	9608401



To learn more or discuss an opportunity about
Fellowes Air Purifiers, please call a
Fellowes representative, 1800 33 11 77 or
contact your account manager:

To watch customer testimonials and get further technical
information, visit us at aeramaxpro.com/au/

Fellowes
Brands. | FAMILY BUSINESS
SINCE 1917