

# *connectaply*®

NATURAL TIMBER PANELLING HAS NEVER BEEN THIS EASY



**AUSTRAL  
PLYWOODS**





# connectaply®

## NATURAL TIMBER PANELLING HAS NEVER BEEN THIS EASY.

Connectaply is a pre-finished plywood panelling system that is perfect for ceilings, soffits and internal walls. Available in 6 decorative finishes, connectaply is backed by a 7 year manufacturer's warranty.

Installation of connectaply couldn't be simpler. The panels 'connect' together whilst providing a 3mm shadow line around each panel. Connectaply is fixed using screws which are hidden by adjoining panels.

### Connectaply FAST FACTS:

- Made from 'A' grade Exterior Hoop Pine plywood
- Unique 3 coat factory finish and 7 year manufacturer's warranty
- Installation is quick and easy, with hidden fixing
- 100% Australian Made with 100% Plantation Hoop Pine
- Acoustic and custom panel options also available on request.
- Connectaply panel dimensions - 2400mm long, 280mm wide and 12.5mm in thickness.

### FIXING DETAIL

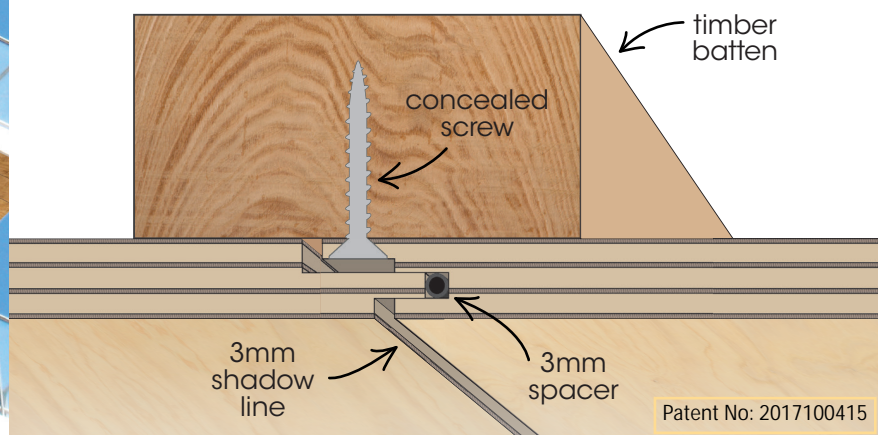

Natural Hoop



Ash



Blackbutt



Spotted Gum



Jarrah



Walnut



Ebony



**AUSTRAL  
PLYWOODS**

[www.australply.com.au](http://www.australply.com.au)

For advice and samples, please contact us on 07 3426 8666