

MATERIALS & FINISHES

- Exposed FaceSet:** 25mm Solid oak 60mm frame & 19mm crown cut oak veneer insert - vertical grain insert
- FaceSet Edging:** NA
- FaceSet Colour / Finish:** TBC
- Hinges / Flap Hinges:** Blum profile softclose & Aventos HK flap stay
- Carcase Material:** Prime melamine white velvet & Exposed carcass crown cut oak veneer
- Carcass Edging:** 1mm White PVC & 2mm Oak Tekton
- Toe Kick Finish:** Solid oak - colour match face set
- Toe Kick Height:** 100mm + 10mm to trim on site
- Drawer Box Set:** Blum Legrabox white 500mm + one SERVO DRIVE for bin
- Drawer Box Set (Inner):** Blum Legrabox white 500mm
- Handles:** Screw on TBC
- Bench Top Material:** Stone
- Bench Top Thickness:** 30mm
- Bench Top Overhang Front:** 5mm to post & 13mm to face set on island
- Bench Top Overhang Ends:** 5mm & 13mm to end panel on island
- Sink Brand / Type:** Burns & Ferrall - Cayman CAB700 - undermount
- LED Lighting:** LED Striplight Profile #14 flat diffuser
- Splash Back:** Tiles

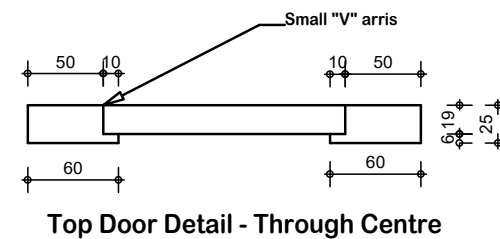
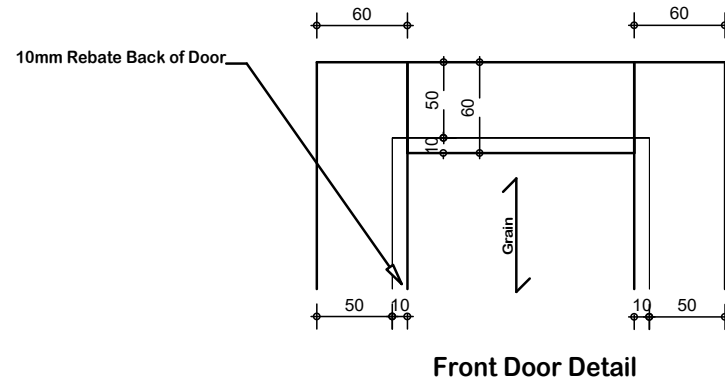

Ph:(09) 443-0296 Fax:(09) 443-0581 Email: design@dbj.co.nz

Note for manufacturer/installers: All appliances and fittings are to be installed in accordance with the appliance/fitting manufacturer's instructions.

These Drawings / Designs Are Copyright.



Name: Cross N		
Project: Cross N-Kitchen		
Scale: 1:20	Sheet 1 of 8	Job 16459
Date: 13/03/2018	Design: DT	Drawn: DC

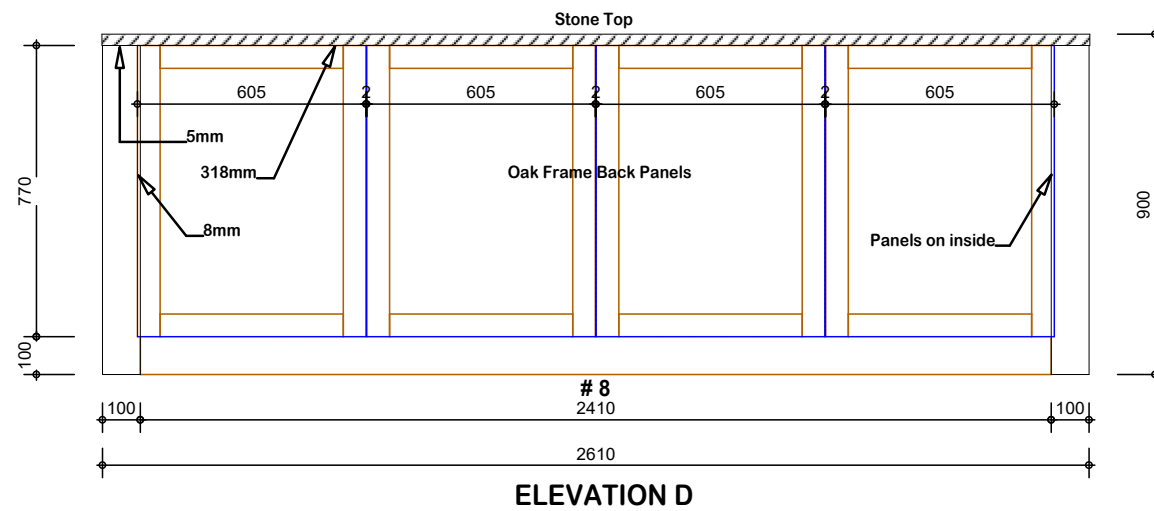
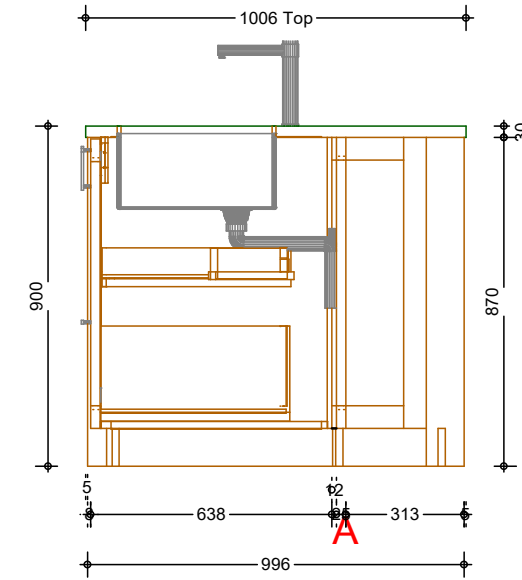
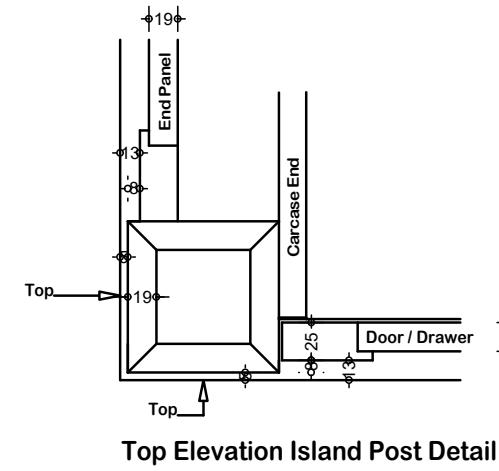
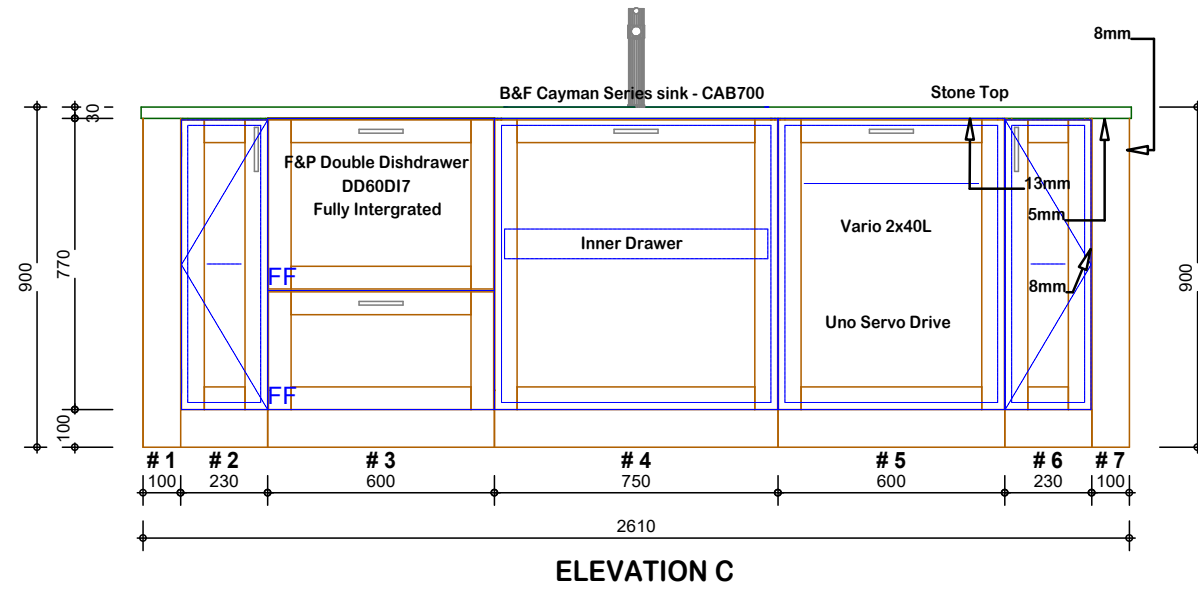

Ph:(09) 443-0296 Fax:(09) 443-0581 Email: design@dbj.co.nz
 Note for manufacturer/installers: All appliances and fittings are to be installed in accordance with the appliance/fitting manufacturer's instructions.

These Drawings / Designs Are Copyright.

A3 <small>DESIGN - BUILD - JOIN</small> DBJ	Name: Cross N		
	Project: Cross N-Kitchen		
	Scale: 1:20	Sheet 4 of 8	Job 16459
	Date: 13/03/2018	Design: DT	Drawn: DC

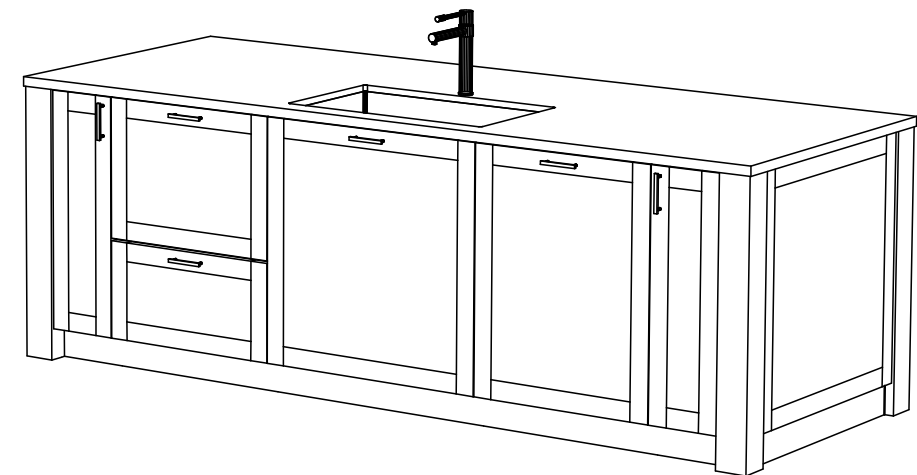
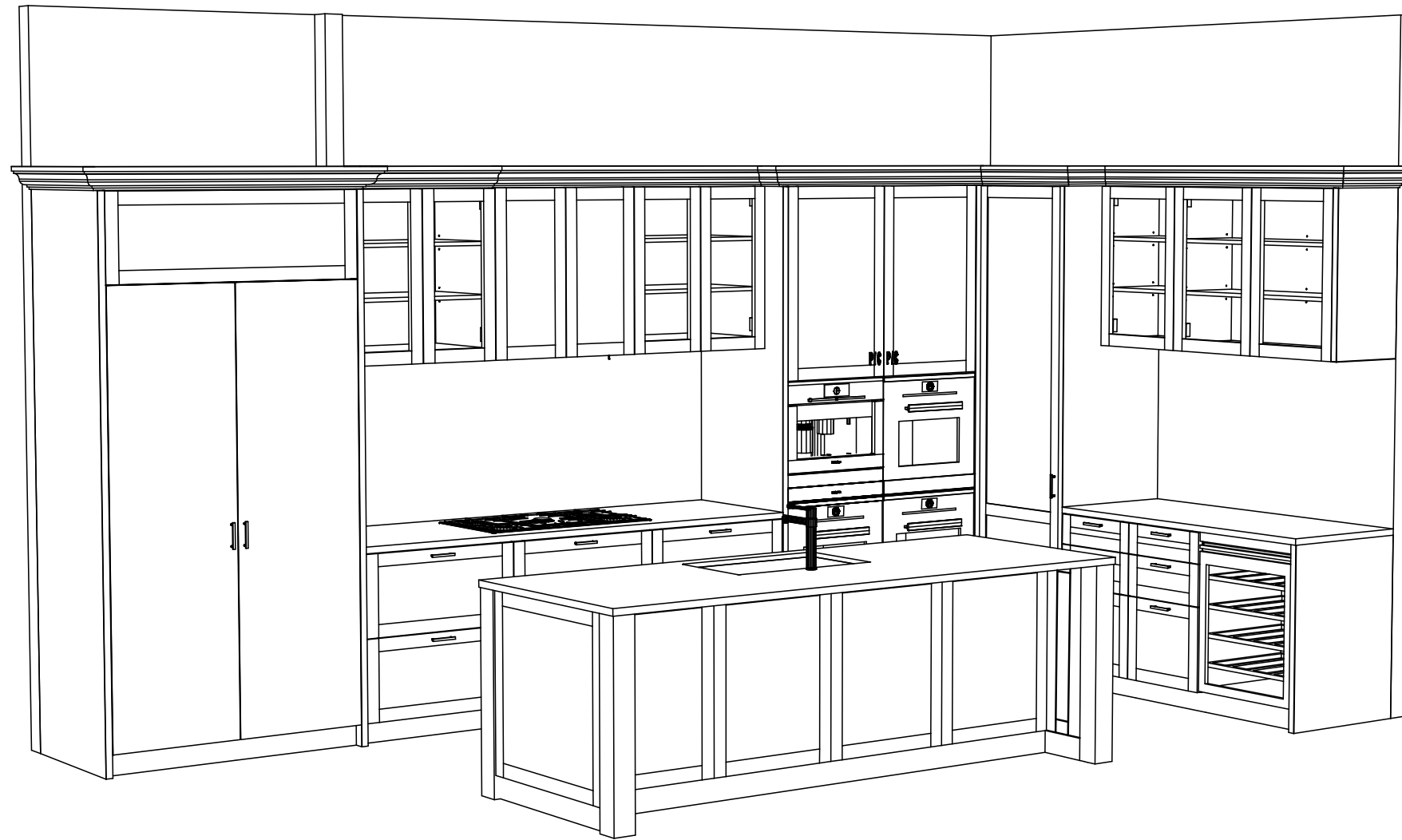

Ph:(09) 443-0296 Fax:(09) 443-0581 Email: design@dbj.co.nz
 Note for manufacturer/installers: All appliances and fittings are to be installed
 in accordance with the appliance/fitting manufacturer's instructions.

These Drawings / Designs Are Copyright.

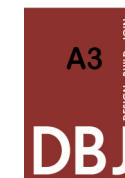

Name: Cross N		
Project: Cross N-Kitchen		
Scale: 1:20	Sheet 5 of 8	Job 16459
Date: 13/03/2018	Design: DT	Drawn: DC