

CYCLE

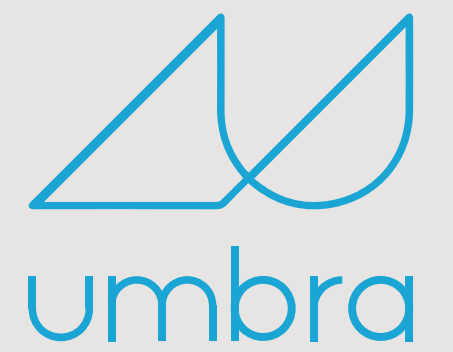

OUTDOOR
LIVING

CYCLE

Adequate comfort of panoramic transparency

Cycle is a vertical guillotine glass system with chain mechanism that is a culmination of this widely utilized modern design concept ensuring maximum transparency and excellent performance with its wide panoramic motorised glass panels.

Flawless design aesthetics offering a smart solution to numerous architectural requirements with simple and contemporary architectural design. The minimal aluminum frame of structure provides availability for an expanded and visually unobstructed perspective.

Cycle can be configured to fit various applications in commercial spaces such as restaurants, hotels, cafes as well as in residential applications.

System features striking elegance and unique facade configurations with its clear and precise lines creating a minimal look and offer a panoramic view in any kind of weather condition.

The movable panels are slid either upwards or downwards and parked behind fixed panel which forms a glass parapet.

Thanks to the full thermal break within the frame and the high specification of glazing used, these guillotine windows have high level of thermal insulation, solar protection and transparency. Different number of glass options are available to provide the needed specific performance.

The system is operated by chain mechanism for ultra-simple control. The motorization of system is fully hidden.

To ensure complete safety, system stops when it meets with an obstacle thanks to smart sensor technology that contributes the safety precautions and make the system highly dependable, durable and performing product.

Additionally smart home automation systems can be integrated as well switch and remote control options, with a touch of a button you can create your desired ambience.





Cycle Guillotine Glass System
 Cycle offers a maximum clear span that provides unobstructed view & minimalistic style. The system is operated by just the touch of button.

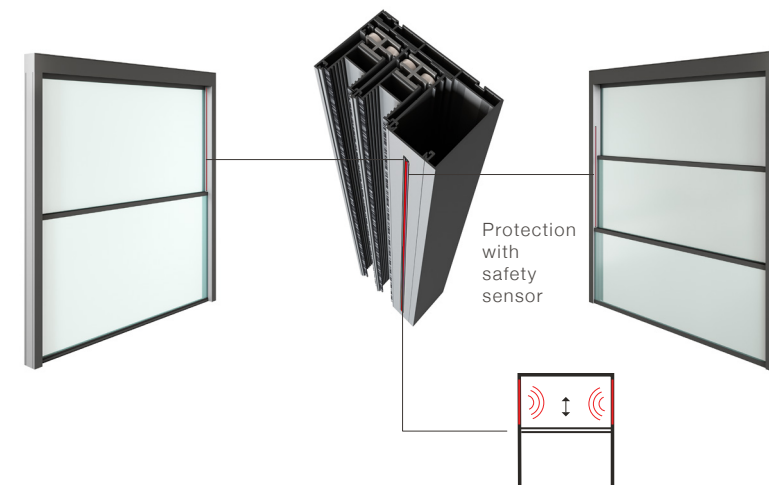
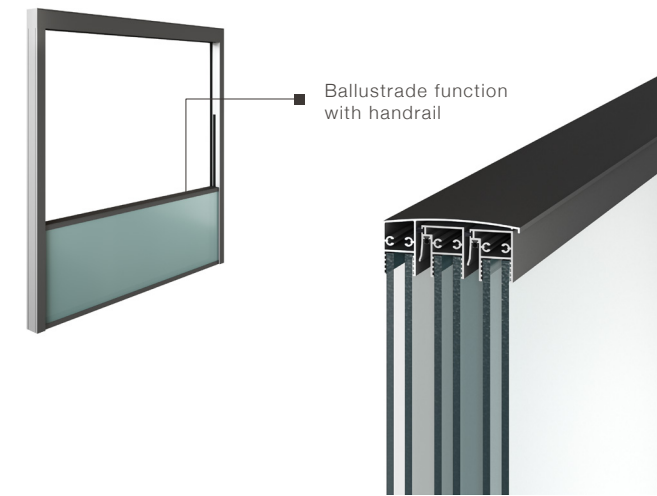

with & without glass options

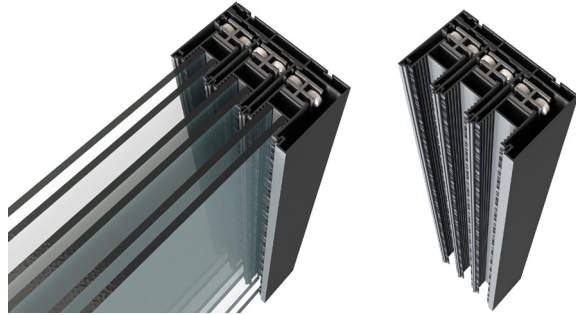

2 & 3 panels options

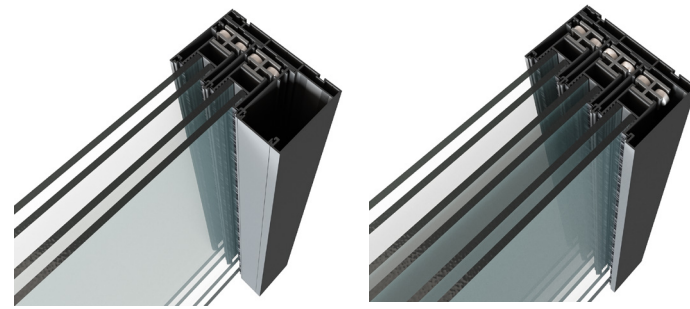

Combination of compact design and high-tech engineering

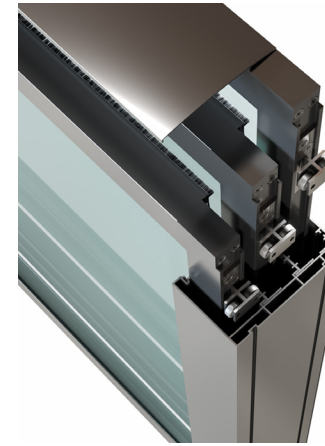

Wide clear span with hidden panel frames

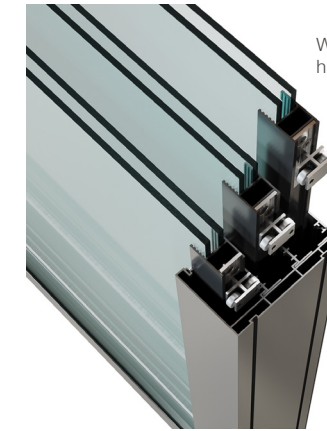

Compact guide profile consisting of four parts for easy assembly & disassembly

Fully hidden strengthened counterweight movement mechanism

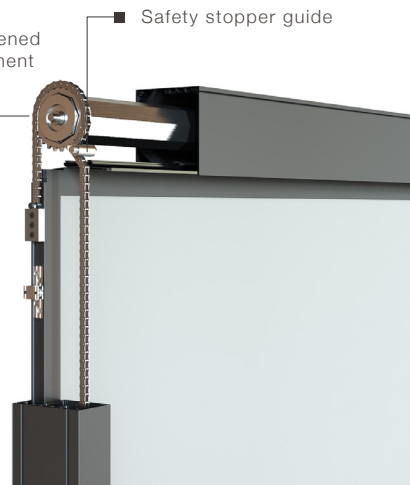

Safety stopper guide

Fully hidden motor drive

Rubber cord and brush for high level insulation



Guide rollers for optimum and smooth running



5+11+5mm tempered insulated double glass

Rubber cord and brush for high level insulation and resistance between glass panels connection



Technical Details

2 Panels

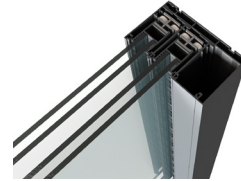

Description	Glazing Type
Glazing	5+11+5mm Insulated.
Max. movable glazed frame weight	110kg
Max. height	300cm
Max. width	400cm (Min width :120cm)
Max. size	12 sqm
Surface finish	Electrostatic powder-coating
Motor type	220 VAC 50/60Hz Tubular motor 85NM or 120NM Direct Drive
Control	Switch, remote or smart control options

Description	Glazing Type
Double Insulated Glazing	5mm T + 11mm air gap + 5mm T

3 Panels

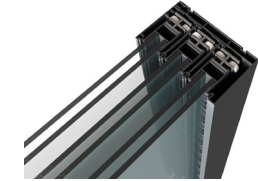

Description	Glazing Type
Glazing	5+11+5mm Insulated.
Max. movable glazed frame weight	220kg
Max. height	350cm
Max. width	400cm (Min width :120cm)
Max. size	12 sqm
Surface finish	Electrostatic powder-coating
Motor type	220 VAC 50/60Hz Tubular motor 85NM or 120NM Direct Drive
Control	Switch, remote or smart control options

Description	Glazing Type
Double Insulated Glazing	5mm T + 11mm air gap + 5mm T

www.umbraoutdoorliving.com.au

info@umbraoutdoorliving.com.au

040 339 88 19

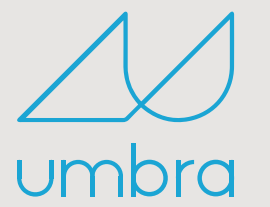

OUTDOOR
LIVING

