

FRAMEE

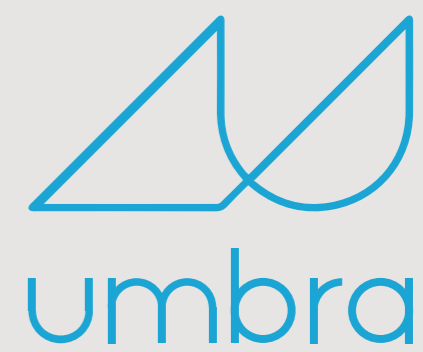

OUTDOOR  
LIVING

---

## FRAMEE

Framee is sliding glass system with fine-framed double glazed panels

System is made of fine-framed aluminum profiles with modern design & suitable especially for large-area applications and completed with stylish and functional accessories perfectly matching with modern architectural living spaces. System offers a comfortable sliding with silent movement and allows individual sliding panels to be moved horizontally to one side or both in parallel.

Framee provides reinforced profile designs for customized static values, condensated frame profile design as well as glazing up to 26mm thickness.

System is ease of install with compact connection details.



# FRAMEE

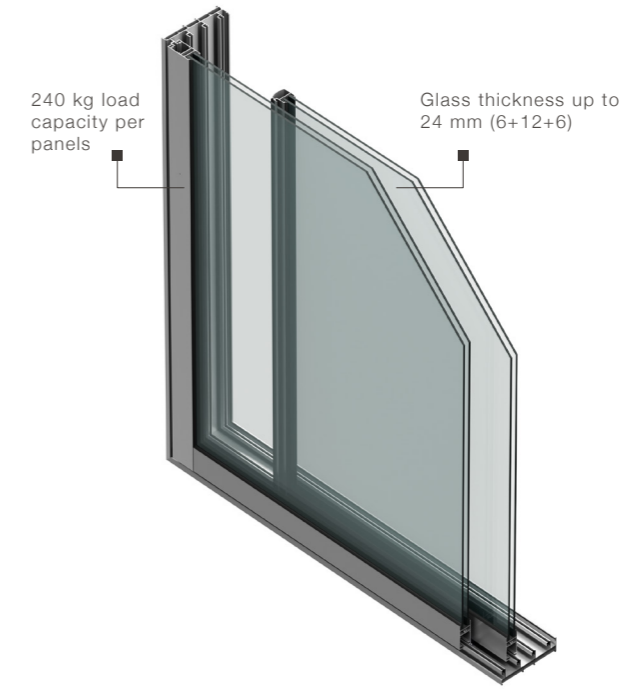
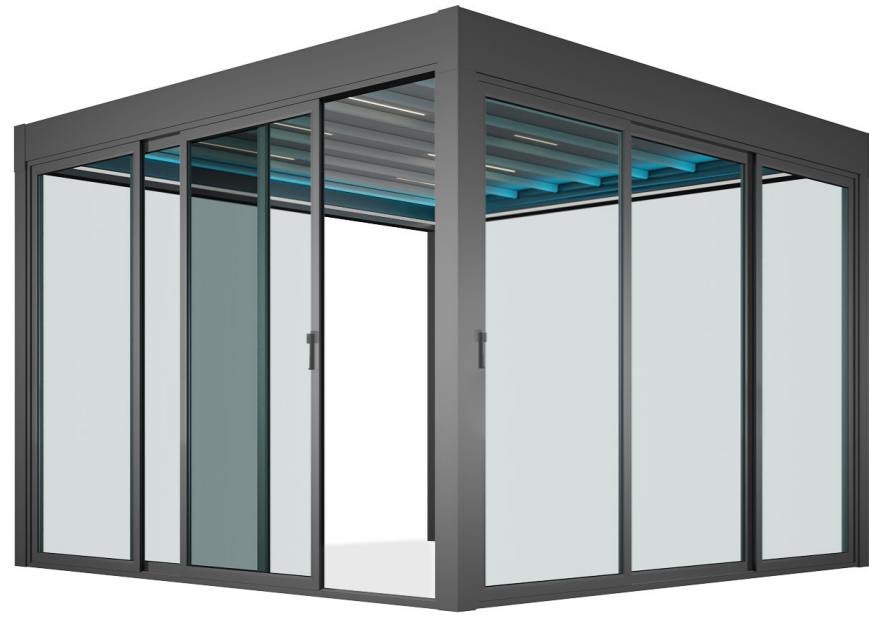

Stainless steel bottom rail for easy and smooth movement

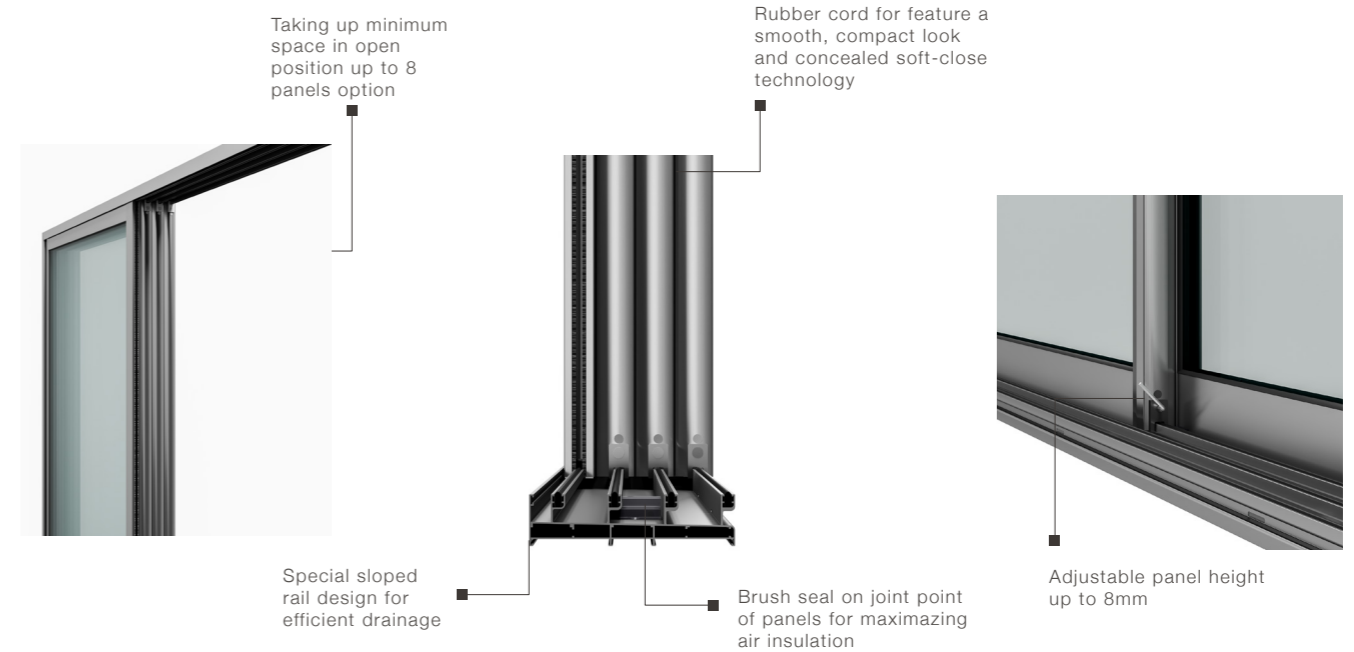
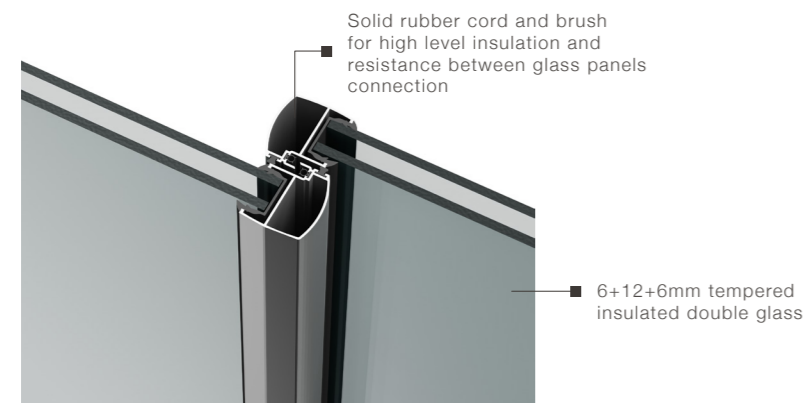

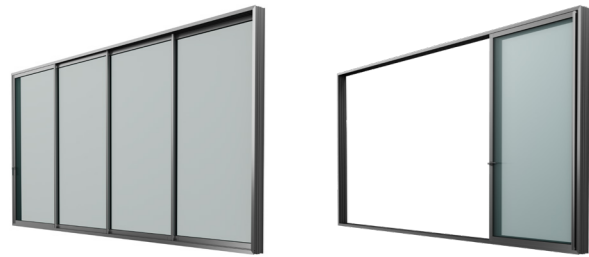

Technical Specifications	Measurements	
System Depth	Frame	81,7/112,6/181,7 mm
	Sash	38 mm
Air Permeability	Opening Sash	24 mm

\* Take double glazing thickness tolerances into consideration.



Performance Criteria	Classification	Test Standards
Thermal Transm. Coeff.*	-	-
Air Permeability	Class 8A (450 Pa)	EN 1026 EN 12207
Water Tightness	Class 4 (600 Pa)	EN 1027 EN 12208
Resistance to Wind	Class B2 (800 Pa)	EN 12210

\* Special condensation calculations for the project were separately carried out.  
\*\* Please contact us to obtain reports that contain the relevant performance values.

## Handles & Lock Positions

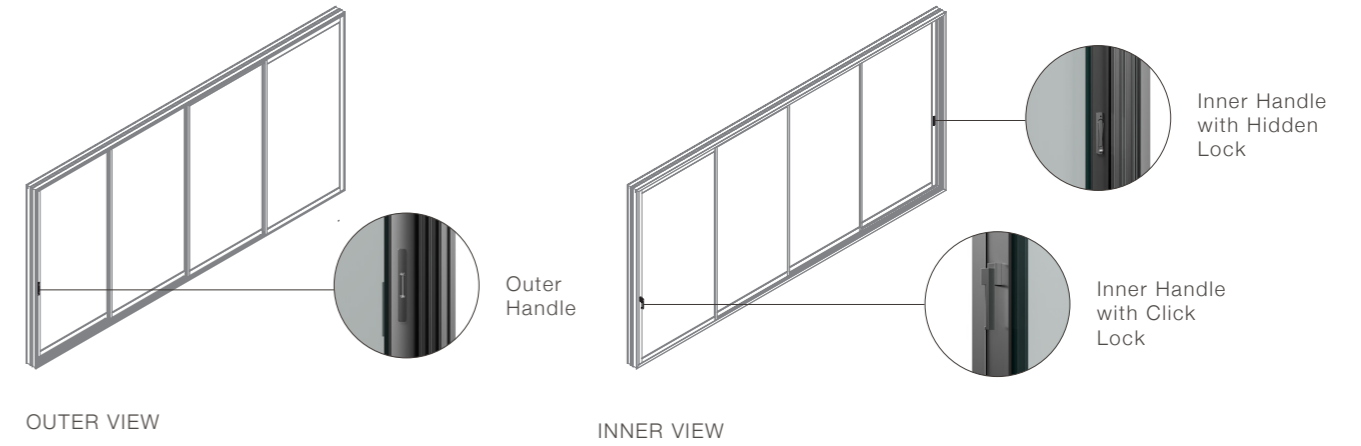

## Handles & Lock Types

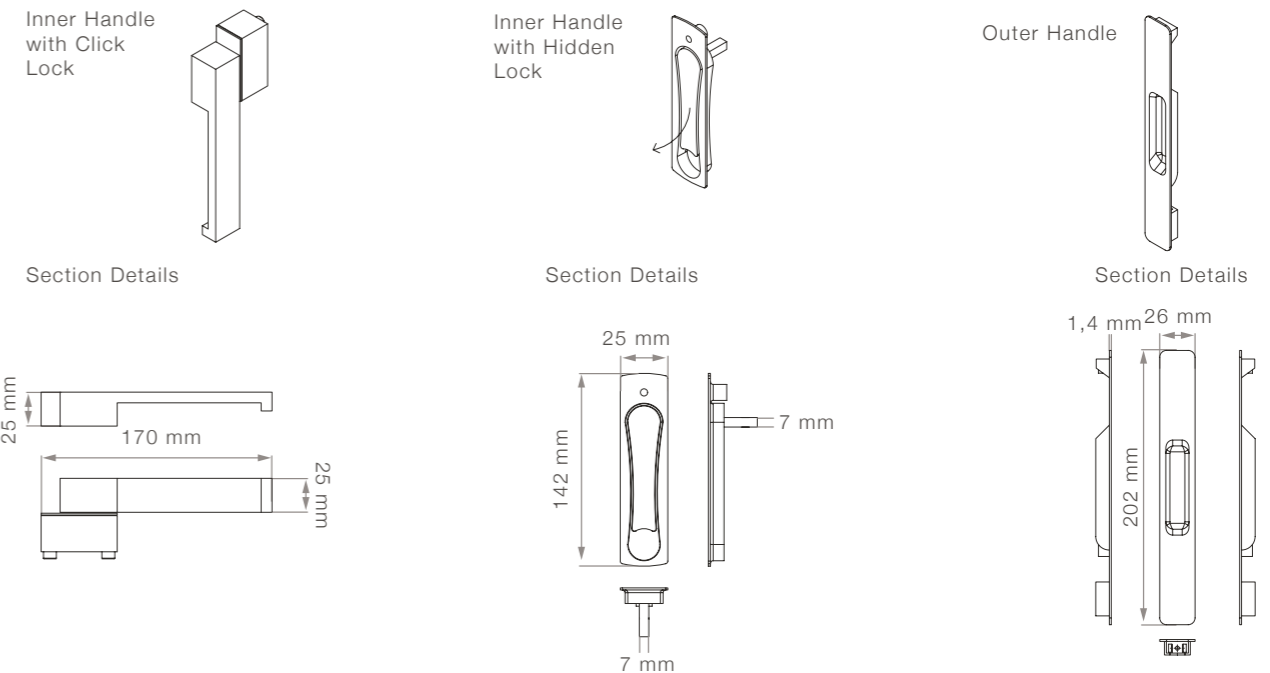

## Anodising Brushed Color Options

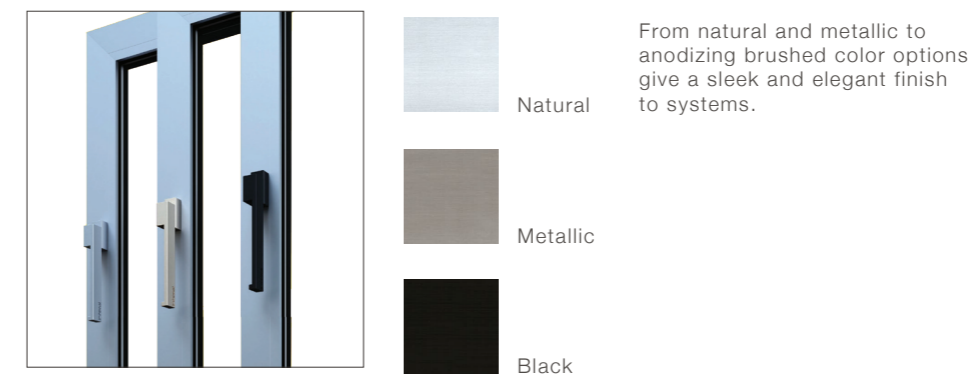

## Technical Details



Glazing	6+12+6 mm insulated double glass
Slide Options	2,3 or 4 panels single slide 4,6 or 8 panels double slide
Max. width for single slide	6000 mm
Max. width for double slide	7000 mm
Max. height	3000 mm
Max. load capacity per panels	240 kg
System depth	Frame 81 mm Sash 38 mm
Surface finish	Electrostatic powder-coating
Control system	Manual
Inner handle with click lock	included
Inner handle with hidden lock	included
Outer handle	included

[www.umbraoutdoorliving.com.au](http://www.umbraoutdoorliving.com.au)

[info@umbraoutdoorliving.com.au](mailto:info@umbraoutdoorliving.com.au)

040 339 88 19

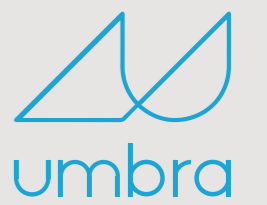

OUTDOOR  
LIVING

