

— *fire* —  
DESIGN  
FOR LUXURY LIVING

ICON  FIRES



# Fire Design For Luxury Living

Icon Fires set the standard for luxury bioethanol fireplaces with advanced levels of performance, functionality and refinement.

Icon Fires make a stylish addition to indoor and outdoor spaces. They open a world of creative scope to push the boundaries of fireplace design.

These flueless, environmentally friendly bioethanol fireplaces employ the latest technologies to achieve best efficiencies, vibrant flames and impressive heating performance. With burners and fireboxes to suit a variety of environments and all equipped with a unique heat and flame controllability feature, an industry first and exclusive to Icon Fires.

Visit [www.iconfires.com](http://www.iconfires.com) for additional resources to help plan your Icon Fires fireplace.

# About Bioethanol Fires

Icon Fires are fuelled with bioethanol. Bioethanol is a biofuel derived from plants including corn, wheat, barley and sugarcane. Bioethanol is a renewable energy source, with no odour and no harmful emissions. It creates a vibrant clean-burning flame with no harmful effects on the environment or the people using it.

Flueless fireplaces allow for endless installation possibilities. Architects, designers and home renovators around the world have embraced bioethanol fireplaces to achieve traditional and minimalist contemporary styles.









# Commercial Range

## Performance driven bioethanol fires ...

Icon Fires Commercial Range offers an Industry first 'performance driven' bioethanol fireplace for indoor and outdoor spaces.

The commercial range is designed for grand spaces delivering large dynamic flames with significant heat output.

The Commercial Linear Burners have controllable flame size achieving temperature control, fuel efficiency and longer burning times, an industry first and exclusive to Icon Fires. You can create a unique fireplace or install them into existing masonry fireplaces.

The Commercial Fireboxes used with the linear burners are available for inbuilt installations. The Commercial Fireboxes capture and direct the significant heat output efficiently into the room. Black interiors enhance the appearance of the flame. The Commercial Fireboxes are equally well suited for minimalist contemporary settings or traditional fireplaces with a mantelpiece.

# Commercial Range



## IFMB614 Mid Burner 614

**Dimensions:**  
H136mm x L624mm x D254mm  
**Cut out Sizes:**  
H105mm x L595mm x D230mm  
**Capacity:** 7.7 litres  
**Consumption:** avg 0.75lt/hr  
**Burning Time:** Up to 10 hours  
**Performance:** 6.5 kW/hr rating

## IFLB914 Long Burner 914

**Dimensions:**  
H136mm x L924mm x D254mm  
**Cut out Sizes:**  
H105mm x L895mm x D230mm  
**Capacity:** 11.5 liters  
**Consumption:** avg 0.9lt/hr  
**Burning Time:** Up to 12 hours  
**Performance:** 10 kW/hr rating

- High performance, clean-burning bioethanol burners.
- Flame and heat control.
- Durable 304 stainless steel construction.
- Twin Skin Top Tray supplied.
- Suitable for custom settings and existing masonry fireplaces.
- Suits indoor and outdoor use.
- All burners come with electronic pump for easy refueling.





## CMFBCLASSIC Commercial Classic Firebox Complete with IFMB614 Burner

Dimensions:  
H600mm x L900mm x D385mm  
Fascia Finishes: ■ □  
Capacity: 7.7 litres  
Consumption: avg 0.75lt/hr  
Burning Time: Up to 10 hours  
Performance: 6.5 kW/hr rating

## CMFBXL Commercial XL Firebox Complete with IFLB914 Burner

Dimensions:  
H600mm x L1100mm x D385mm  
Fascia Finishes: ■ □  
Capacity: 11.5 liters  
Consumption: avg 0.9lt/hr  
Burning Time: Up to 12 hours  
Performance: 10 kW/hr rating

- Supplied complete with a matching burner.
- Directional-Convection system.
- Choice of fascia: Black or Brushed Stainless Steel.
- Interior finish: Black.
- Suits indoor and outdoor use.

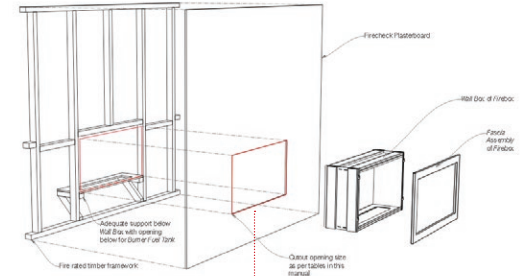

**IMPORTANT**  
Insulation must be  
securely wrapped  
around the firebox body  
before placing inside  
opening

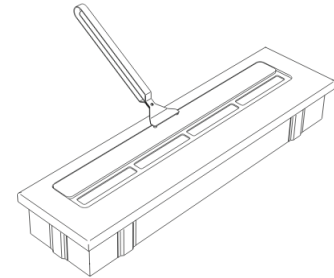

Flame height and heat control are a feature of all  
Icon Fires linear burners.  
Improving comfort and fuel efficiency.



# Slimline Range



## It's the attention to detail ...

The Slimline range offers the industry's longest linear burners that produce a stretched continuous flame for dramatic effect. All burners are designed for custom installations both indoor and outdoors.

Fine detail and quality finishes distinguish Slimline Burners. The unique mounting frame enables flush fitting into the surface. Elegant proportions and the brushed stainless steel accentuate the long continuous flame.

Complementing the Slimline Linear Burners are matching Fireboxes designed for inbuilt installations. Their shallow depth simplifies fitting into compact settings.

Black interiors enhance the flame's appearance. With a choice of brushed stainless steel or black fascias to finish off the setting.

Simple installation opens up endless positioning possibilities for Icon Fires Slimline Range.

# Slimline Range



## SB500 Slimline Burner

**Dimensions:**  
H100mm x L545mm x D145mm  
**Cut Out Size:**  
H110mm x L530mm x D130mm  
**Capacity:** 2.75 Litres  
**Consumption:** avg 0.3 lt/hr  
**Burning Time:** Up to 8 hours  
**Performance:** 2.7 kW/hr rating



## SB800 Slimline Burner

**Dimensions:**  
H100mm x L845mm x D145mm  
**Cut Out Size:**  
H110mm x L830mm x D130mm  
**Capacity:** 4.5 Litres  
**Consumption:** avg 0.6 lt/hr  
**Burning Time:** Up to 8 hours  
**Performance:** 5.4 kW/hr rating

## SB1100 Slimline Burner

**Dimensions:**  
H100mm x L1145mm x D170mm  
**Cut Out Size:**  
H110mm x L1130mm x D155mm  
**Capacity:** 6.25 Litres  
**Consumption:** avg 0.9lt/hr  
**Burning Time:** Up to 9 hours  
**Performance:** 7.7 kW/hr rating

## SB1400 Slimline Burner

**Dimensions:**  
H100mm x L1445mm x D170mm  
**Cut Out Size:**  
H110mm x L1430mm x D155mm  
**Capacity:** 8.15 Litres  
**Consumption:** avg 1.0 lt/hr  
**Burning Time:** Up to 9 hours  
**Performance:** 9.8 kW/hr rating

- High efficiency, clean-burning bioethanol burners.
- Flame and heat control.
- Slender dimensions allow for compact installations.
- Brushed finish, 304 Stainless steel construction.
- Suitable for custom settings and existing masonry fireplaces.
- Suits indoor and outdoor use.
- All burners come with electric pump for easy refueling.

Slimline Burner Image  
SB1400 has dual sliding  
plate, smaller models have  
single sliding plate





# Slimline Range Double Sided



## SLIMFBDS1100 Slimline Firebox Double Sided Complete with SB800 Burner

Dimensions:  
H600mm x L1100mm x D450mm  
Fascia Finishes: ■ □  
Capacity: 4.5 Litres  
Consumption: avg 0.6 lt/hr  
Burning Time: Up to 8 hours  
Performance: 5.4 kW/hr rating

## SLIMFBDS2000 Slimline Firebox Double Sided Complete with SB1400 Burner

Dimensions:  
H600mm x L2000mm x D450mm  
Fascia Finishes: ■ □  
Capacity: 8.15 Litres  
Consumption: avg 1,0 lt/hr  
Burning Time: Up to 9 hours  
Performance: 9.8 kW/hr rating

## SLIMFBDS1350 Slimline Firebox Double Sided Complete with SB1100 Burner

Dimensions:  
H600mm x L1350mm x D450mm  
Fascia Finishes: ■ □  
Capacity: 6.25 Litres  
Consumption: avg 0.9 lt/hr  
Burning Time: Up to 9 hours  
Performance: 7.7 kW/hr rating

## SLIMFBDS2000 800 Slimline Firebox Double Sided Complete with 2 x SB800 Burner

Dimensions:  
H600mm x L2000mm x D450mm  
Fascia Finishes: ■ □  
Capacity: 4.5 Litres per SB800 Burner  
Consumption: avg 0.6 lt/hr per SB800 Burner  
Burning Time: Up to 8 hours per SB800 Burner  
Performance: 5.4 kW/hr rating per SB800 Burner\*\*

## SLIMFBDS1650 Slimline Firebox Double Sided Complete with SB1400 Burner

Dimensions:  
H600mm x L1650mm x D450mm  
Fascia Finishes: ■ □  
Capacity: 8.15 Litres  
Consumption: avg 1,0 lt/hr  
Burning Time: Up to 9 hours  
Performance: 9.8 kW/hr rating

- High efficiency, clean-burning bioethanol burners.
- Flame and heat control.
- Slender dimensions allow for compact installations.
- Brushed finish, 304 Stainless steel construction.
- Suitable for custom settings and existing masonry fireplaces.
- Suits indoor and outdoor use.
- All burners come with electric pump for easy refueling.

Slimline Burner Image  
SB1400 has dual sliding  
plate, smaller models have  
single sliding plate

\*\* Please note KW/hr should be  
calculated by the combination of  
both burners.



**CMFBDSCLASSIC**  
Commercial Classic Firebox  
Double Sided Complete with  
IFMB614 Burner

Dimensions:  
H600mm x L900mm x D450mm  
Fascia Finishes: ■ □  
Capacity: 7.7 Litres  
Consumption: avg 0.75 lt/hr  
Burning Time: Up to 10 hours  
Performance: 6.5 kW/hr rating

**CMFBDSXL**  
Commercial XL Firebox  
Double Sided Complete with  
IFLB914 Burner

Dimensions:  
H600mm x L1100mm x D450mm  
Fascia Finishes: ■ □  
Capacity: 11.5 Litres  
Consumption: avg 0.9 lt/hr  
Burning Time: Up to 12 hours  
Performance: 10.0 kW/hr rating

- Fireboxes in contemporary stretched linear formats.
- Supplied complete with a matching burner.
- Shallow depth simplifies installation.
- Choice of fascia: Black or Brushed Stainless Steel.
- Interior finish: Black.
- Suits indoor and outdoor use.

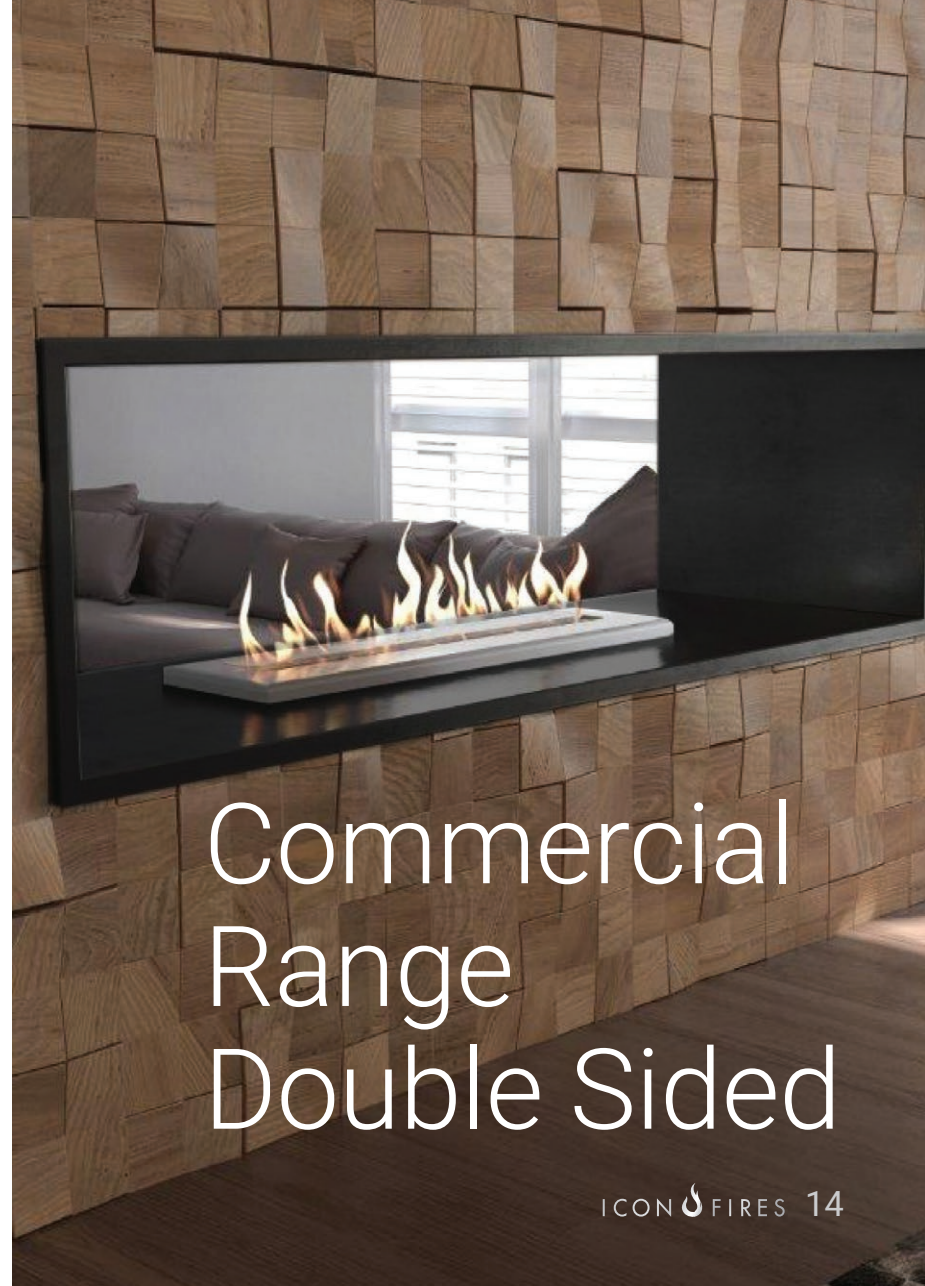

# Commercial Range Double Sided







# Nero Wall Fires

It simply mounts on the wall ...

Mounting a fire setting onto an interior wall is an exciting new way to bring a decorative fire into a living space.

Nero Wall Fires hang from a simple to fit wall bracket.

The slender proportions of the Slimline Burners allow for an unobtrusive installation with Nero projecting just 170mm off the wall.

Nero Wall Fires are available in three sizes to match the Slimline Burners in 800mm, 1100mm and 1400mm.



Flame stability, efficiency, fuel economy and heat output are all enhanced with the latest burner technologies employed across the Icon Fires range.

Heat output and flame effect can be controlled with all Icon Fires burners. An industry first and exclusive to Icon Fires for this style of burner.

# Nero Wall Fires



- Supplied complete with matching burner.
- Choice of fascia: Black or Stainless Steel.
- Interior finish: Black.
- Suits indoor use only.

## Nero 1150 Complete with SB800 Burner

**Dimensions:**  
H590mm x L1150mm x D170mm  
**Fascia Finishes:** ■ □  
**Capacity:** 4.5 Litres  
**Consumption:** avg 0.6 lt/hr  
**Burning Time:** Up to 8 hours  
**Performance:** 5.4 kW/hr rating

## Nero 1450 Complete with SB1100 Burner

**Dimensions:**  
H590mm x L1450mm x D195mm  
**Fascia Finishes:** ■ □  
**Capacity:** 6.25 Litres  
**Consumption:** avg 0.9lt/hr  
**Burning Time:** Up to 9 hours  
**Performance:** 7.7 kW/hr rating

## Nero 1750 Complete with SB1400 Burner

**Dimensions:**  
H590mm x L1750mm x D195mm  
**Fascia Finishes:** ■ □  
**Capacity:** 8.15 Litres  
**Consumption:** avg 1.0 lt/hr  
**Burning Time:** up to 9 hours  
**Performance:** 9.8 kW/hr rating

### DISCLAIMER\*

Specifications are subject to change without notice.  
Current specification documentation can be obtained from [www.iconfires.com](http://www.iconfires.com)

For more information visit  
[www.iconfires.com](http://www.iconfires.com)  
or contact us at [info@iconfires.com](mailto:info@iconfires.com)

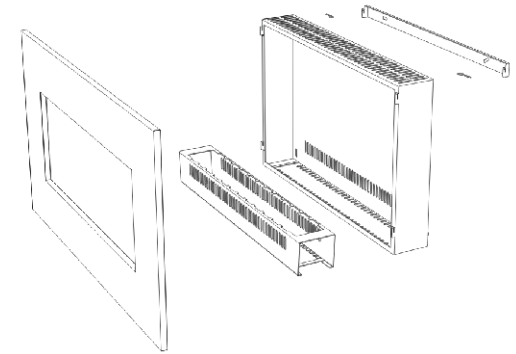

Slender proportions, minimal projection off the wall.

ICON  FIRES

[www.iconfires.com](http://www.iconfires.com)