

INNOVATIONS 2025

THE ARCHITECTURAL KITCHEN

LEICHT[®]

CONTENTS

WELCOME	02-03
GEO	04-07
MIRO	08-11
HANDLE CONCEPT Q	12-15
NEW COLOURS AND DECORS	16-31
KYOTO OPEN FOR LAMINATE AND LACQUER PROGRAMMES	32-35
WALL-MOUNTED SIDE PANEL SHELF UNITS	36-39
WORKTOPS	40-45
UNITS AND ACCESSORY	46-49
SURROUND SINKS AND TAPS	50-51
HANDLES	52
DISCONTINUATION	55

BALANCING STARTING PRICES AND PREMIUM



GEO is captivating with a unique 3D structure that reflects the vertical structure design trend.

RETHINKING THE STRUCTURE



The relief structure of GEO is created by deep embossing. The interplay between matt and glossy surfaces has a lively visual effect. The appearance changes delightfully depending on the viewing angle.

GEO was deliberately made available in the colours K 131v sander and K 133v ember. Both colours blend perfectly into a low-contrast colour scheme. The light sander shade is captivating with its soft beige colour and can be beautifully combined with light shades and materials. The darker ember shade, on the other hand, opens up a second level of earthy and pastel colours.

GEO is a plain-coloured programme and therefore has no continuous direction of pattern, neither vertical nor horizontal.

The ideal accessory surround for GEO has a smooth finish and in the case of sander corresponds to our 136 sand grey and in the case of ember to our 139 lava.

Programme: GEO
Programme no.: 224 | 424 | 724
Price group: 1

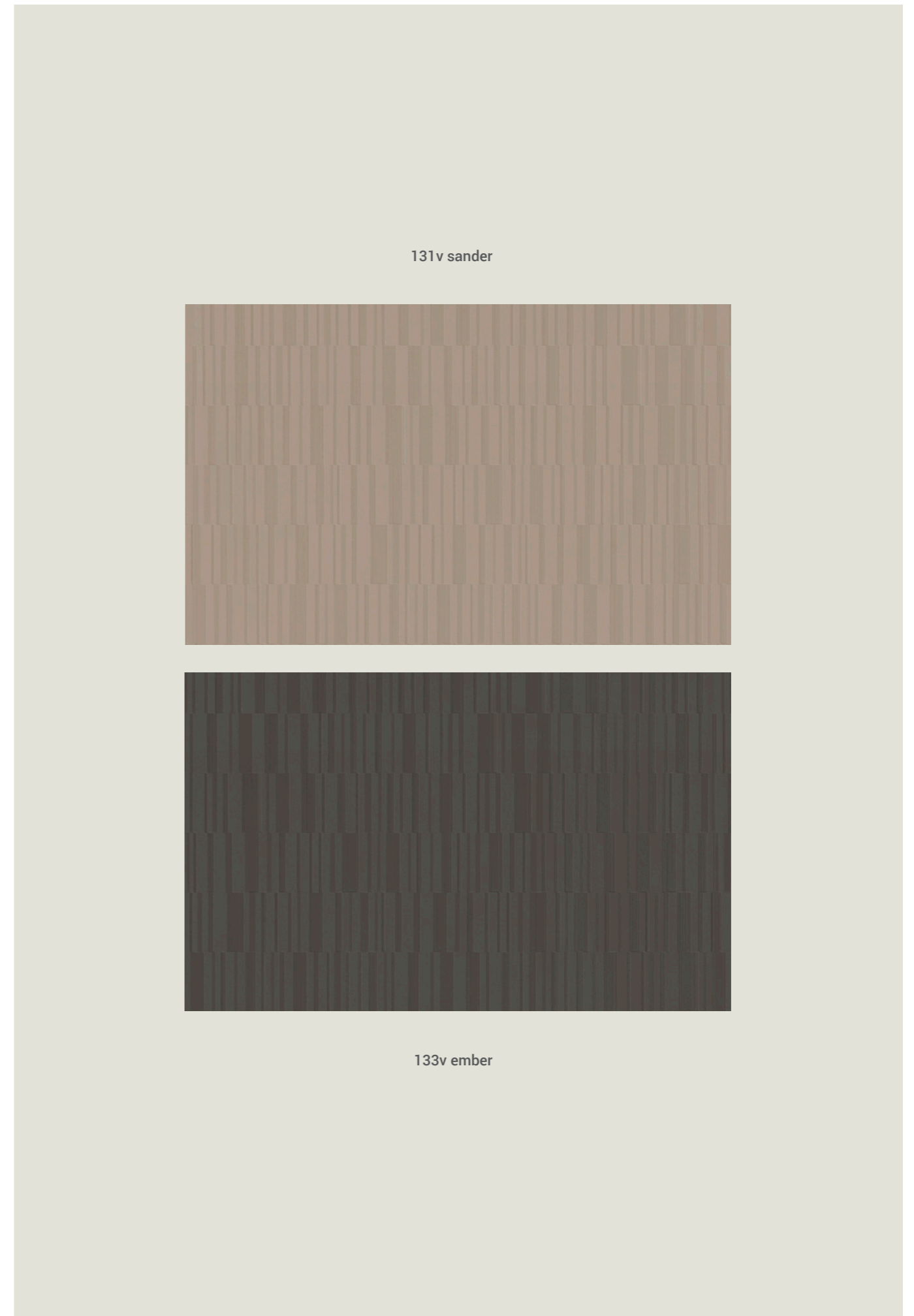

MIRO PROGRAMME



MIRO – our new laminate product with surrounding edges and a narrow edge radius. Timelessly modern, with a robust surface and appreciated by customers.

SPECIAL FEATURES / NOTES



We are really striking a chord with the times with the new surface MIRO. A product that is uncomplicated in terms of argumentation and highly appreciated by end customers in terms of its surface quality. The product is covered on both sides with HPL laminate in a thickness of 0.6 mm. The front has a soft matt finish for a pleasant look and feel. The back has a matt texture and is the same colour as the front. The surrounding edges in high-quality ABS design have a round and narrow edge radius and match the front colour.

In terms of colour, the permitted accessory surround is available as a K surround in melamine quality or FS matt lacquer.

The MIRO programme can be combined with all handle types and therefore offers maximum design flexibility.

Programme: MIRO
 Programme no. 255 | 455 | 755
 Price group: 1

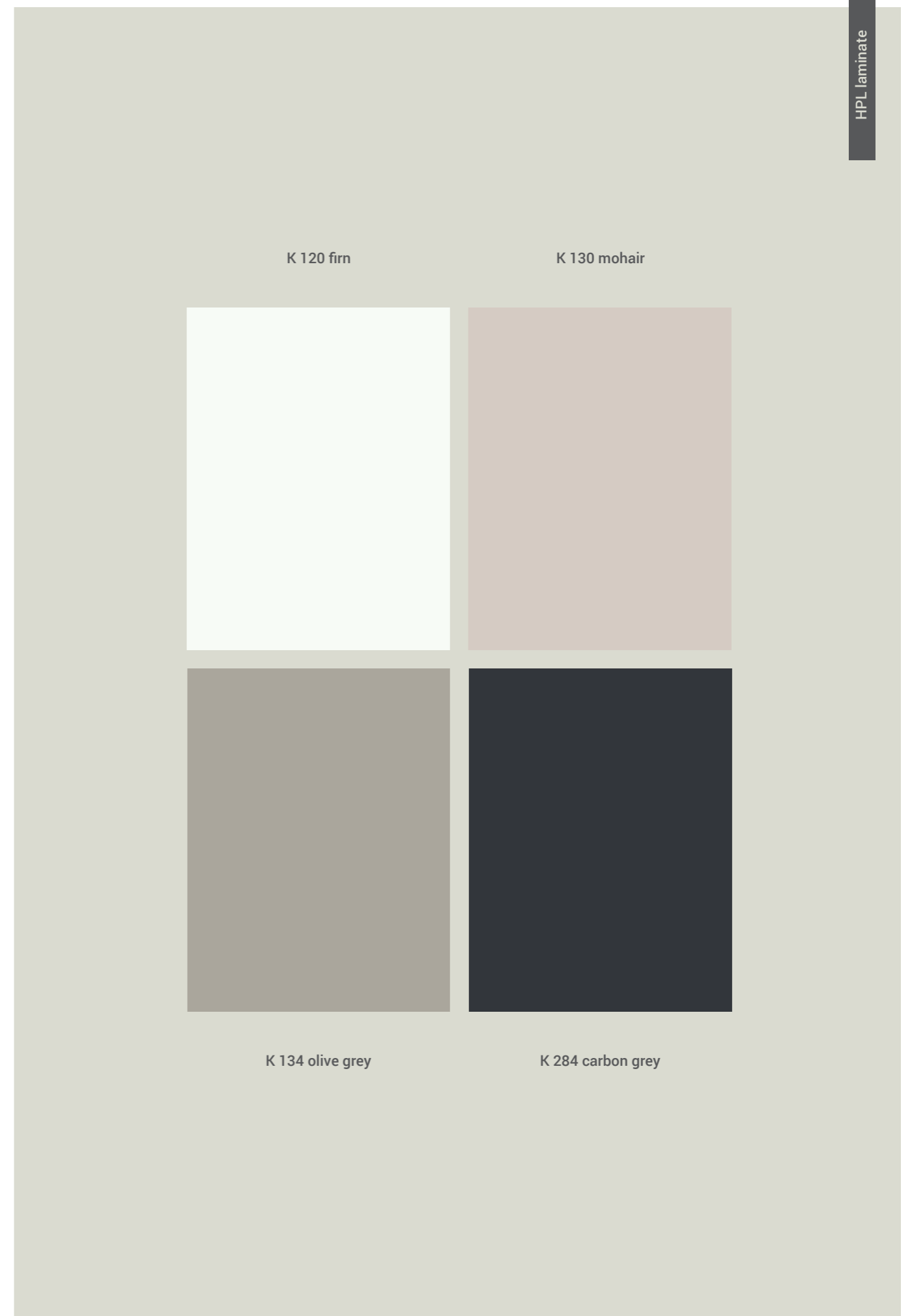

Q HANDLE CONCEPT



The Q handle concept embodies a harmonious fusion of form and function, defined by refined details and aesthetic subtleties. The distinctive wave-shaped recess not only offers an appealing visual aesthetic, but also an ergonomic user experience.

WHEN HANDLE AND FRONT MERGE



The Q programmes offer a wide range of colour and texture options with the diverse selection of real wood veneer and lacquer. The integration of the handle developed in-house into the wave-shaped structure is particularly striking. Thanks to its ingenious design, the handle blends seamlessly into the shape and emphasises the organic aesthetic of the design.

The Q programmes are available in the design line PRIMO and P1. Due to its position, the handle can be accessed from above and below and is available in the two colours 416 bronze dark and 417 steel black.

The Q handle concept is possible in the surfaces 211 CLASSIC-FF-Q, 214 CLASSIC-FS-Q, 270 TOPOS-Q and 267 TERMA-Q. The programmes are indicated with the suffix "Q". In terms of price, the veneered Q programmes are in a separate price group, which includes the additional price for the handle. The lacquer programmes, however, require a surcharge for the handle. The handle is only available in handle position D. The handle is only approved for front widths >30 cm.

Programmes:

- 211 CLASSIC FF-Q (PG 3)
- 214 CLASSIC FS-Q (PG 4)
- 270 TOPOS-Q (PG 6)
- 267 TERMA-Q (PG 7)

SPECIAL FEATURES / NOTES

AREAS OF APPLICATION AND RESTRICTIONS:

- The Q handle concept is only available for matt lacquer and veneered programmes
- The handle is assembled at the factory
- Only handle position D (central arrangement) possible
- A "KT ejector" is recommended in the case of fridges and fridge-freezer combinations
- The width of the front can be changed
- Permissible for floor units, tall units and wall units

HANDLE COLOURS

- 416 bronze dark
- 417 steel black

UNITS NOT AVAILABLE:

- Programme glass doors
- Single tall unit fronts
- Excluded for unit widths <30 cm
- T...ZR Pullout floor unit
- T...ZH Towel unit
- TH...73S Hob unit
- TE...K Carousel unit
- HGT... Appliance fronts
- HV...Slide-away door unit
- HFV...Fold-away door unit
- H...GVZE Tall pullout unit
- H...GVZ2 Tall pullout unit
- TSS, OSS, ESS... Two-door sliding door unit
- GFV... Front for built-under appliances with "door hinges L/R
- TSP ... Z2W 100 width – refuse bin
- TSP ... Z2W 120 width – refuse bin
- GMN, IGMNU Catch for interior drawers
- Front combination ANFK1/2
- O...PG Glass door wall units
- O...AK Accent glass wall unit
- GFR ... / GF... Appliance front for large capacity appliance
- ANGTRAUS... Cutout for wine cooler
- HDT... Access doors
- OE..., OE...T2 Corner wall units
- ANFK1, ANFK2... Front combinations

HANDLE POSITIONING Q HANDLE CONCEPT

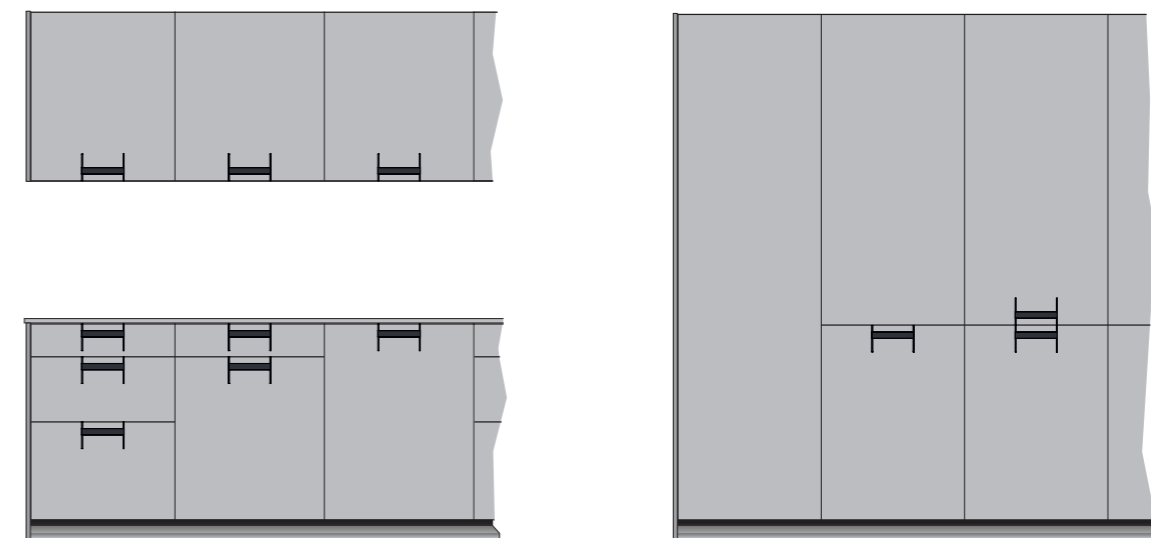

NEW COLOURS AND DECORS

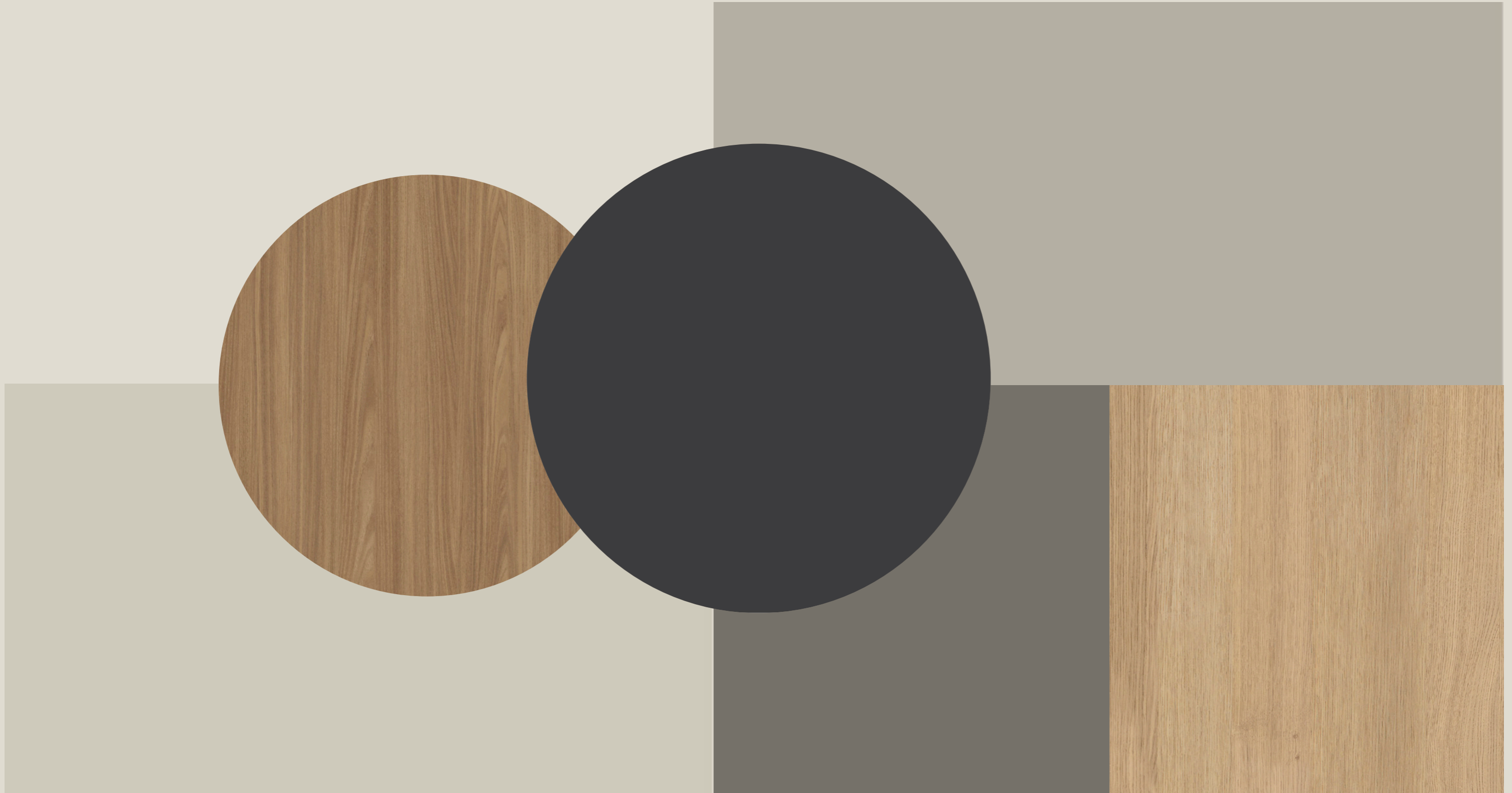

celano walnut

ORLANDO

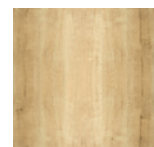

karst oak

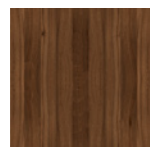

walnut le midi

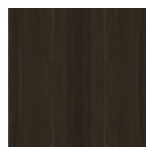

black walnut



mountain robinia



celano walnut
NEW

256v celano walnut

A timeless elegance thanks to a combination of simple and calm decor in a natural reproduction of European walnut.

With the colour 256v celano walnut, we are expanding our colour range in the ORLANDO programme to include a light walnut colour, which can be skilfully combined with both lighter and darker plain colours from LEICHT. The large figures are used in a discreet manner, giving the decor a soft and unemotional effect. The laminate front with melamine resin coating has the same decor on the front and back. Surfaces in KI design feature matching grain.

Programme: ORLANDO
Programme no.: 219 | 419 | 719
Price group: 1

256v celano walnut





cashmere

The new combination colour

CERES | BONDI | CLASSIC-FF | CLASSIC-FS | CARRÉ-FS
VERVE-FS | LARGO-FG | IOS | IOS-M | AVENIDA

126 cashmere

The new colour cashmere adds a light, harmonious beige tone to the LEICHT world of plain colours. The shade creates an inviting atmosphere that combines particularly well with light woods and stone. The colour tone is absolutely neutral and is synonymous with restrained interior design, satisfying the need for low-contrast, gentle planning. The new colour 126 cashmere appears timelessly elegant in combination with soft, warm, non-contrasting colours and materials and creates a stylish ambience in a room. With its slightly higher proportion of grey, the beige cashmere tone clearly distinguishes itself from the familiar warm beige and grey colours such as mohair, sand grey and olive grey in the plain colour palette of LEICHT.

The shade cashmere is a LEICHT-own colour creation and thus initially exclusive.

Price group: 1 | 2 | 3 | 4 | 5 | 6

126 cashmere





northern oak

TOPOS

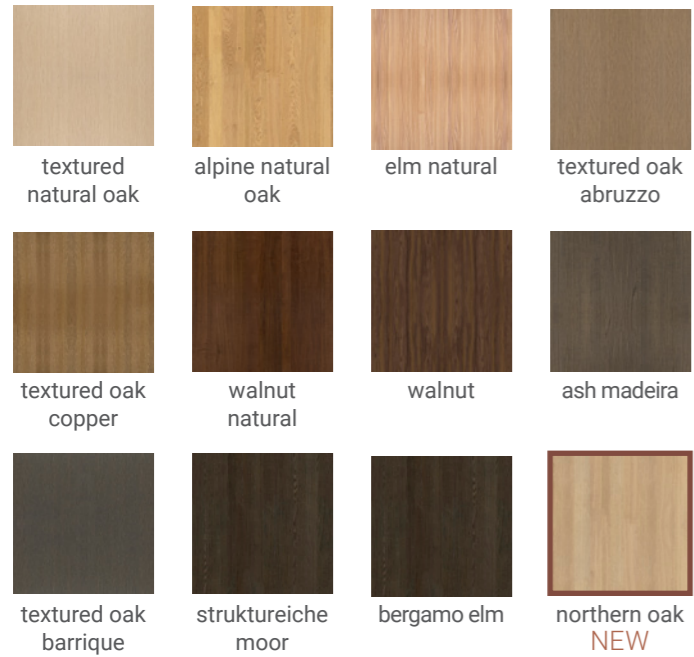

HI 315v northern oak

Our colours in the genuine wood programme TOPOS are being extended by a light, cooler and natural real wood front with vertically veneered European oak and a striking brushed surface. The decor shows a calm composition of figures without knots.

Programme: TOPOS
Programme no.: 269 | 469 | 769
Price group: 5

In comparison with our colours H 222h textured natural oak and HI 319v alpine natural oak, HI 315v northern oak is distinguished by its light tone and texture and can be considered somewhere between the other two decors. In HI 315v northern oak, we have succeeded in incorporating an oak with a reduced "yellow" colour range, which therefore allows new colour combinations in the classic oak decor range.

HI 315v northern oak



crystal and agate

PEARL

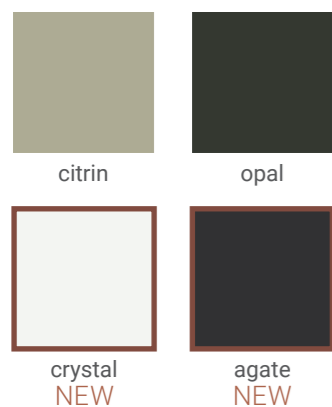

PM 072 crystal and PM 073 agate

By adding two new colours to the PEARL programme, we are taking a necessary step towards completing the range. These new colours are the perfect complement to the existing shades and open up completely new design possibilities. The characteristic DNA of PEARL, the metal effect, remains unchanged. Our lightest new colour PM 072 crystal is captivating with its white purity and the incomparable depth effect in the suitably colour-coordinated acrylic glass, accompanied by a subtle metallic shimmer. With the colour PM 073 agate, we are enriching the PEARL programme with an elegant, deep metallic anthracite with matching grey-transparent acrylic glass. Like the existing colours, both colours come with an anti-fingerprint finish.

ME accessory surround and
K accessory surround
072 crystal – ME 772 | K 120
073 agate – ME 773 | K 284

Programme: PEARL
Programme no.: 240 | 740
Price group: 4

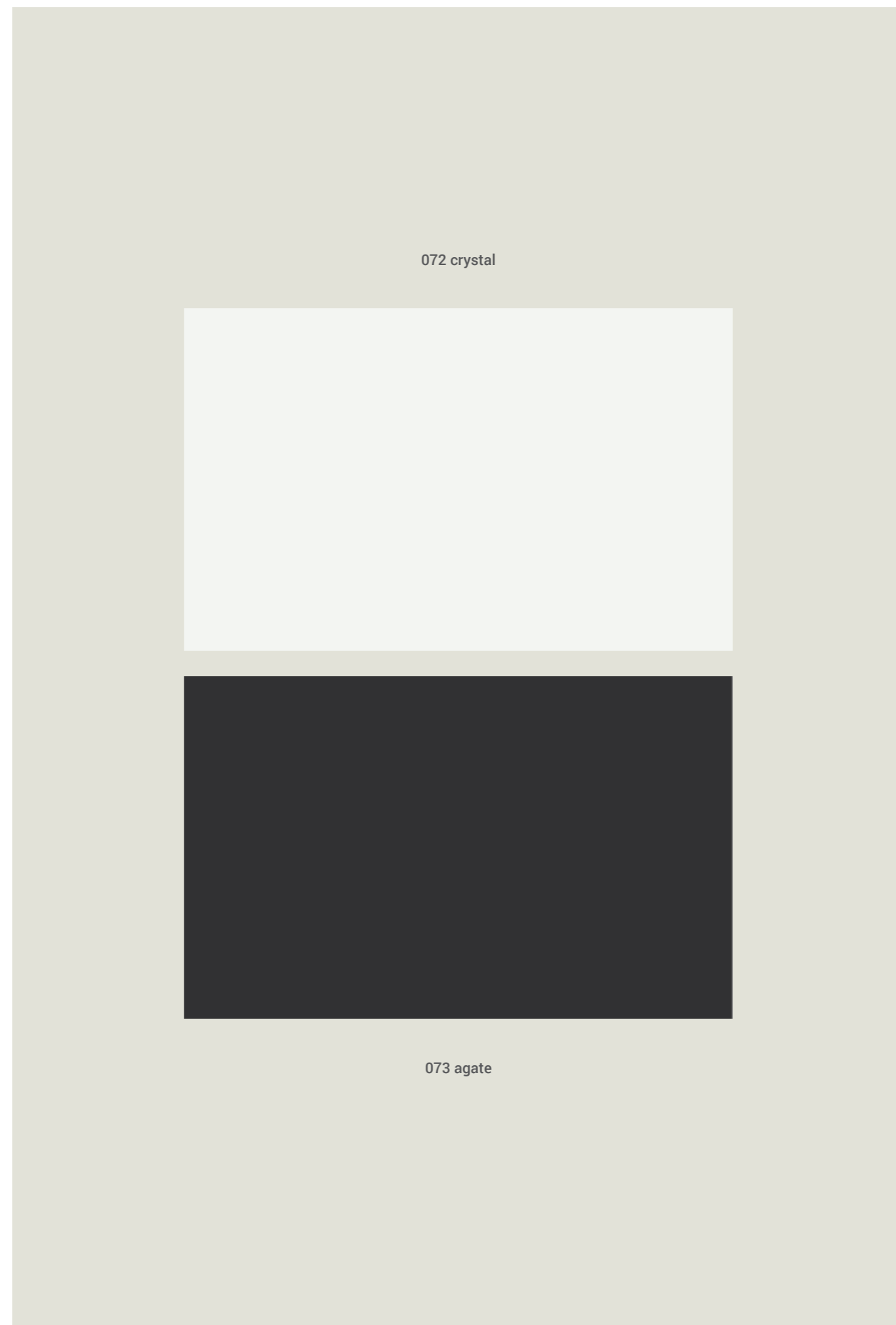

steel shadow

LAIKA



copper shadow



lava shadow



steel shadow
NEW

MC 199 steel shadow

The new colour MC 199 steel shadow is adding a stylish anthracite-coloured shade to the LAIKA programme. The dark colour of steel shadow emphasises the special metallic finish with a shadow-like, iridescent effect. The special combination of grinding pattern and lacquering process gives each front a unique surface character. The back is colour-coordinated. The handcrafted manufacturing process gives every single front an individual nature and a unique appearance. The different textures of the individual fronts give each kitchen an unmistakable appearance. The new colour MC 199 steel shadow complements the existing shades copper shadow and lava shadow with a striking black steel look and can therefore be perfectly combined with dark colours and woods.

Programme: LAIKA
Programme no.: 210 | 410 | 710
Price group: 6

MC 199 steel shadow

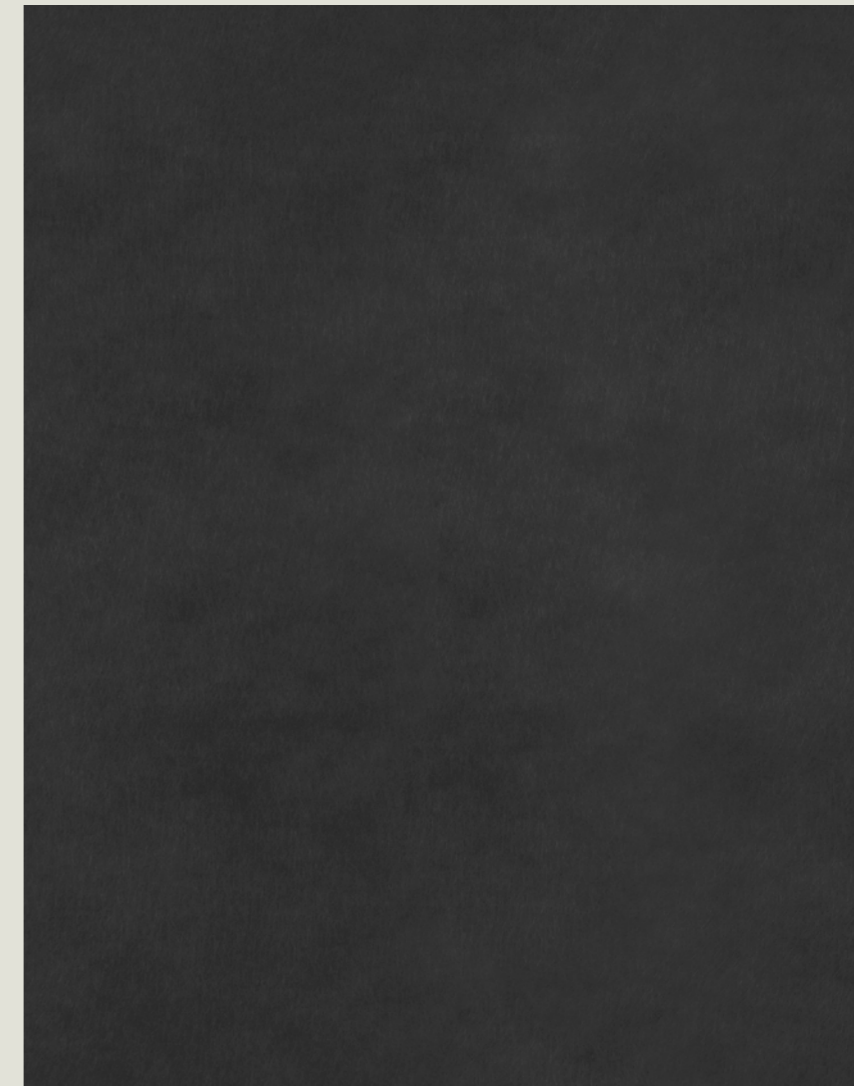

DISCOVER THE NEW DIMENSION OF KYOTO: KITCHENS WITH A FRAME LOOK BUT IN PG1



We are introducing a further development of our KYOTO planning programme inspired by Japanese craft culture. It combines traditional values with a modern aesthetic. From now on, we are opening up the design principle of KYOTO for other programmes. This enables increased flexibility and design variety. The characteristic look of KYOTO with its spatial grid structure can now also be transferred to a high number of programmes. This gives planning a special, high-contrast surface and a frame look that combines different surfaces.

Due to the admission of the programmes CERES, BONDI, F45, etc., the KYOTO design principle can now be planned from PG 1.



PLANNING TIPS AND ORDERING

New-look KYOTO. Making it possible to combine different materials in KYOTO enables a wide range of creative solutions. The handles in alpine natural oak and walnut natural as well as the W2D10 side panels and B2V7 shelves in KH and H design can continue to feature the same decor or be combined with plain colours. This opens up unimagined possibilities. The depicted composition in red, blue and yellow, inspired by Piet Mondrian, is a symbolic possibility that demonstrates what is possible.

New possibilities:

W2D10 - H 319 | H 320 | KH 247 | KH 240
B2V7 - H 319 | H 320 | KH 247 | KH 240

Handle no. 661.319 alpine natural oak
Handle no. 661.320 walnut natural

The following programmes are excluded:
AVENIDA, BAHIA, BOSSA, CARRÉ-FS, IOS, IOS-M, KERA, KYOTO, ROCCA, VALAIS, VERVE-FS

HANDLES

661.319
alpine natural

661.320
walnut natural

PROGRAMMES PLAIN COLOURS

233 CERES
255 MIRO
215 SIRIUS
239 BONDI
212 CLASSIC-FF
254 TOCCO
253 F45
240 PEARL
213 CLASSIC-FS

PROGRAMMES DECORS I VENEERS

H 319 alpine natural oak
KH 247 summer oak

H 320 walnut natural
KH 240 walnut le midi

SIDE PANELS SHELVES

H 319 alpine natural oak
KH 247 summer oak

H 320 walnut natur
KH 240 walnut le midi

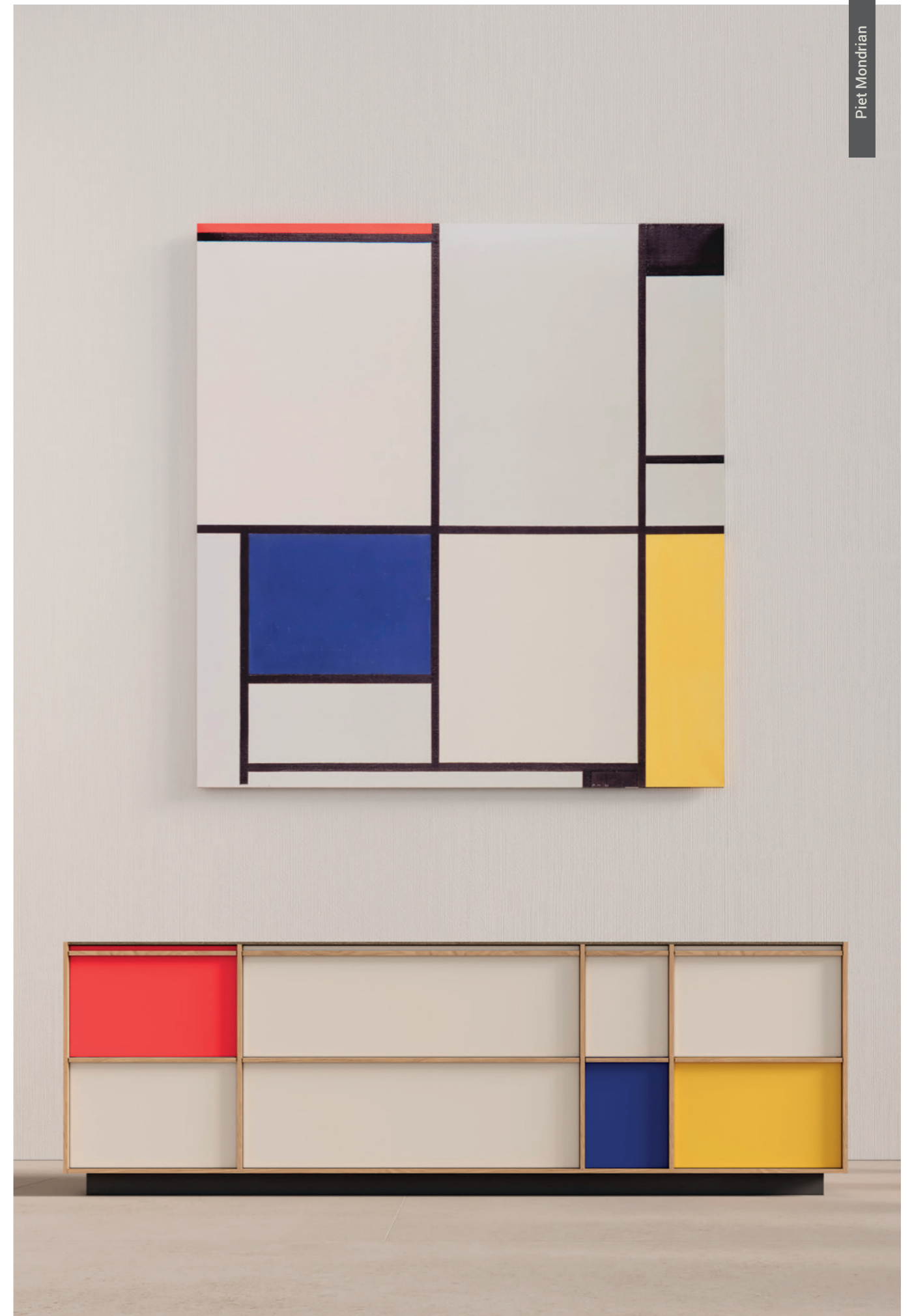

WALL-MOUNTED SIDE PANEL SHELF UNITS WITH VERO FRAMED GLASS DOOR



Shelves provide open storage spaces and create a clear visual structure in the room thanks to their often symmetrical arrangement.

However, the working areas of a kitchen definitely need closed spaces, too. As a visual alternative to classic wall units, the combination of overhanging or wall-mounted side panel shelf units with elegant Vero glass doors offers a new planning approach.

SIDE PANEL SHELF UNITS WITH VERO GLASS DOOR MODULE



The Vero glass doors are positioned flush between the side panels. The holders for the hinges of the Vero glass doors are fitted in the shelves of the side panel shelf unit. These shelves are shortened accordingly.

When open, you do not see a classic unit placed between the sides of the shelf unit, but only the sides and shelves of the unit as well as the chosen material of the wall on which the shelf is mounted.



PLANNING TIPS AND ORDERING

The following general procedure applies

- You plan the W3 side panel shelf unit
- You decide between which two shelves the Vero glass door module W3W VE is required.
- With type ANOW3WOR, W3 side panel shelf units up to 119 cm high and 38 cm deep can now also be planned as wall-mounted without a rear panel with an invisible suspension fitting in the side panel.

In general, the familiar range of materials for the W3 side panel shelf unit is also permitted for this planning concept. The same is true of the permissible colours for the Vero frame

- 405 stainless steel
- 416 bronze dark
- 417 steel black

The following heights and widths are permitted with regard to the dimensions of Vero glass doors:

Heights:
53 | 66 | 73 | 80 | 86 | 93 | 146 | 153 | 190 | 197 | 204 | 210 | 217 | 224 cm

Widths:
45 | 50 | 60 cm

Special dimensions are not permitted for the Vero framed glass doors!

As is customary with side panel shelf units, this planning concept also offers the possibility to integrate light in the Vero glass door module. In standard designs, the Vero glass door module is only available with glass shelves in depths of 36 cm or 58 cm.

For aesthetic reasons, we recommend glass shelves. If different shelf depths are planned, wooden shelves are used in the desired design. In this case, use type W3W VE U. The wooden shelves are 1.6 cm thick. This planning concept cannot be implemented with the ICONIC shelving system.

IMPORTANT NOTE:

This planning concept is based on the standard widths of the Vero glass doors (45, 50, 60 cm). In conjunction with the left and right side panels, this results in a side panel shelf unit width that does not always match the overall width of the corresponding planned floor unit row. Below are some examples of how implementation is planned.

The combination of Vero framed doors in standard widths with the W3 side panel modules is characteristic of the system. A shelf arrangement defined in this way must be planned separately from the vertical joint patterns of the furniture, as the width grid of the shelves (door plus side panel) does not correspond to the width grid of the units. This contrast is intentional, as it underscores the different emphasis of these elements.

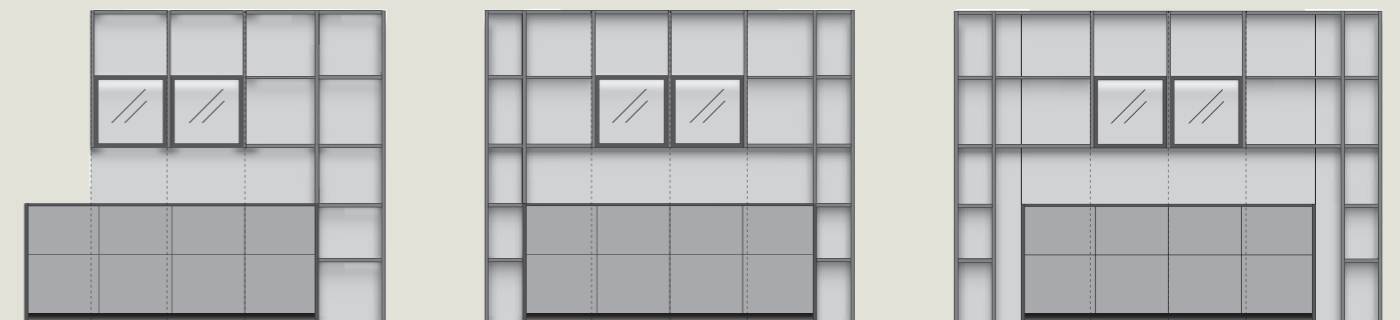

WORKTOPS



Discover the new generation of worktops that combine the best of aesthetics, functionality and durability. Compact worktops feature PP edges for the first time. A new look – closer to the original than ever before.

COMPACT-STONE-DESIGN WORKTOP



Among other things, the value of a kitchen is also significantly influenced by the materials used for the worktops. With our new range of compact worktops in 10 mm material thickness, we offer an alternative to ceramic and natural stone worktops. Thanks to a special embossing technique, the texture of the surface is very close to comparable structures of the original material. The choice of decor follows the standard colours of ceramic or natural stone worktops.

The new offer is made possible by the use of an HPL compact worktop.

Disadvantage of compact worktops: the black core is visible and can contrast with the colour of the selected surface.

NEW:
LEICHT covers the edges of the compact worktops with laminate edges in the same colour and texture. This gives the worktop the same look all round and makes it virtually indistinguishable from the original materials. All housing units (flush-mounted and built-under sinks, hob cut-outs) are still easy to implement. Structural adaptation is trouble-free. This presents a clear alternative in terms of price. LEICHT's existing range (11 colours) is being extended with the following colours:

- K450 KPK pietra serena
- K451 KPK botticino terrazzo
- K457 KPK turco argento
- K462 KPK nero portoro



Worktops

Compact worktop

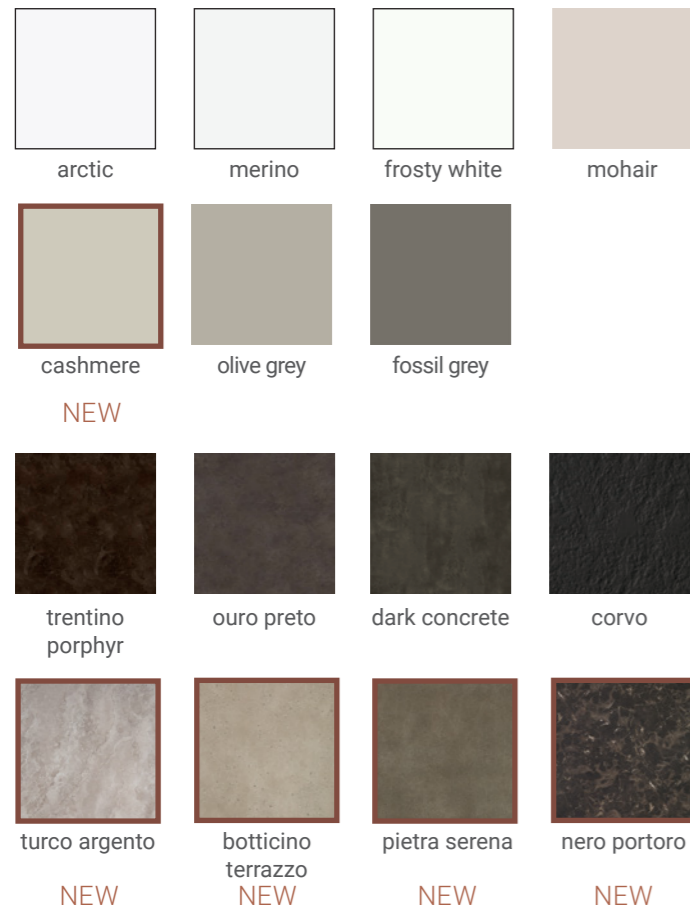

K450 KPK pietra serena

K451 KPK botticino terrazzo



K457 KPK turco argento

K462 KPK nero portoro

UNITS AND ACCESSORY SURROUND



VERO DESIGNED FOR PASS-THROUGH

Our Vero tall units are the basis for this. These can now be designed as pass-throughs with ANDUVE. This means that the unit is fitted with additional hinges. This necessitates an additional Vero door FT**VE without a front. When ordering, please specify whether the door hinge is to be on the right or left.

75 CM

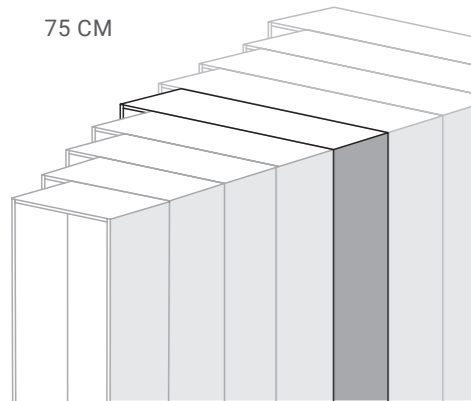

UNIT WIDTH 75 CM

We are keeping pace with the development of the market for 75 cm wide appliances by the appliance manufacturers and have extended our modular appliance housing unit and modules to a width of 75 cm. In addition, further 75 cm wide tall units are now available as standard to continue to guarantee full planning freedom.

FLOOR UNITS FOR HOB EXTRACTOR

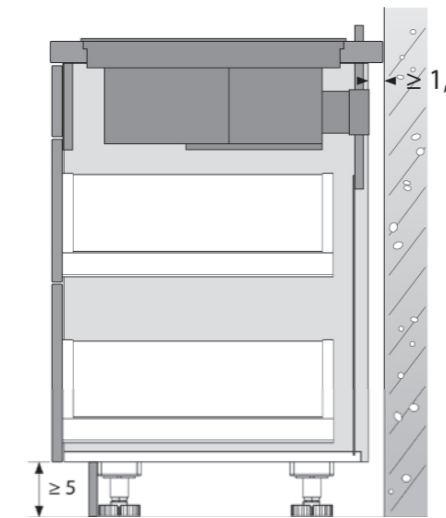

TU... Unguided air circulation

FOR APPLIANCES WITH UNGUIDED AIR CIRCULATION

Simple solution: in appliances with unguided extracted air, the purified air is channelled via a short duct behind the unit where it disperses independently.

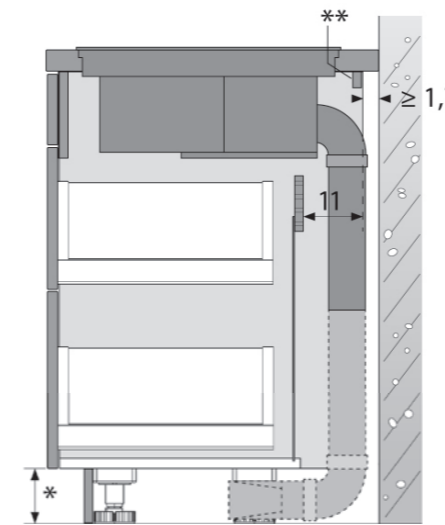

TV... Guided air circulation

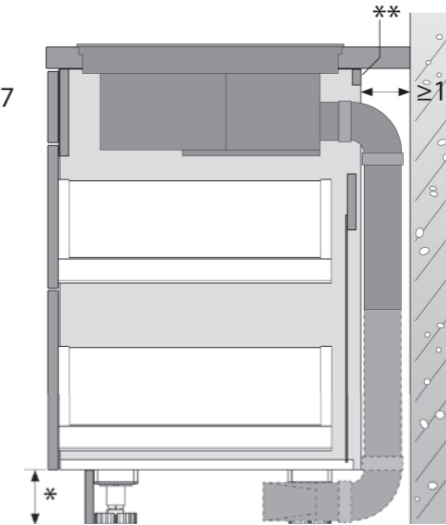

TW... Guided air circulation

FOR APPLIANCES WITH GUIDED AIR CIRCULATION/ EXTRACTED AIR

Controlled and defined air extraction: the air is immediately channelled into the plinth area. The extracted air duct can be installed either in the unit (TV, drawing on the left) or behind the unit (TW, drawing on the right).

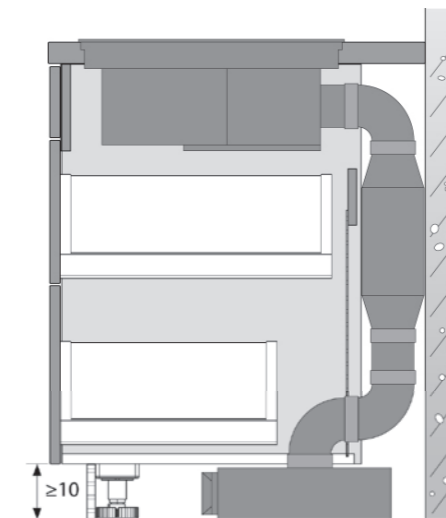

ANTILGER... Guided air circulation

KITCHEN RUN OR ISLAND PLANNING FOR HOB EXTRACTOR WITH PLINTH MOTOR

At LEICHT, the top-quality units are planned individually irrespective of whether they are intended for a kitchen run or island planning, for hob extractors with plinth motor or a special shape.

NOTE
LEICHT designs the hob units dimensioned without a fixed shelf below the hob. This prevents heat build-up, makes maintenance work easier and maintains the given storage height. The rear wall of all hob units can be removed from the inside.

FOLD-AWAY DOOR SYSTEM



Our fold-away door systems now offer even more flexibility and innovative solutions for kitchen and living room furniture. These modern door systems make it possible to elegantly conceal function units or compact kitchen runs, such as kitchenettes, behind large tall unit doors. The fold-away wings can be pushed together in one fluid movement and stowed in a side pocket, making them practical and space-saving.

SPECIAL FEATURES:

- Handle-less design: our fold-away doors are now available in a handle-less design. This popular aesthetic innovation ensures a minimalist and modern appearance.
- Combined fittings for 3-door systems: the 3-door systems consist of one fold-away door system fitting as well as one slide-away door fitting.
- Maximising door extension AN TU85
- Shelf reinforcement profile HFVPR
- Black fitting design
- Fittings assembled in the factory

Two-door HFV2 from 120 to 140 cm

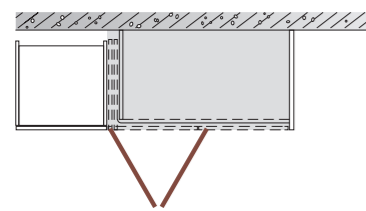

Three-door HFV3 from 180 to 210 cm

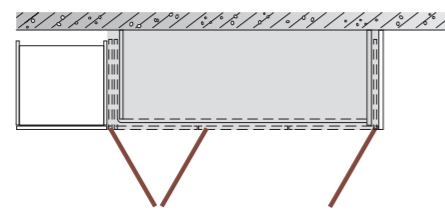

Four-door HFV4 from 240 to 280 cm

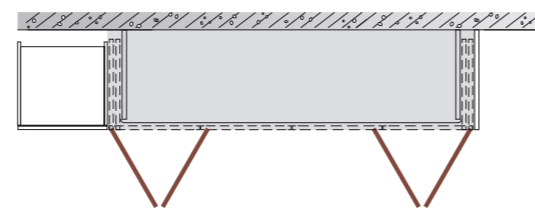

LIGHTING & BALLAST TECHNOLOGY



LIGHT BRIDGE

Our new light bridge floats freely in the room on the ceiling above an island design. There, the light bridge in 405 stainless steel and 416 steel black provides up to 19 watts of dynamic light on the worktop, which can be skilfully controlled via micro switches on the lamp. The 23 cm deep shelf with a load capacity of up to 15 kg also offers space for ingredients.

Luminous colour: 2700 K - 6500 K Shelf:
ESG safety glass with a satin finish
Height: 880, 1080 mm
Width: 600, 1000 mm
Depth: 230 mm

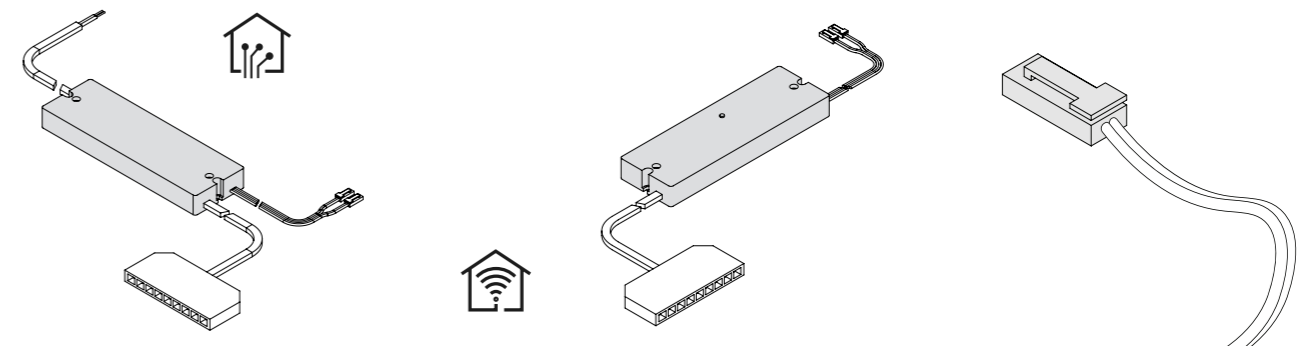

L24CD – LED DYNAMIC LIGHT CONTROL DALI CONTROLLER SET

Controller for controlling all our LL luminaires in the L24 system via house control with DALI DT8 protocol and KNX modules. This controller must be commissioned by qualified personnel.

L24CD
2-pole, DALI controller with 9-fold distributor for connection to power supply unit L24 NT ..

L24CSH – LED DYNAMIC LIGHT CONTROL SMART HOME CONTROLLER

Controller for controlling all our LL luminaires in the L24 system with Smart Home (Alexa, Google, Apple) via ZigBee standard. An additional ZigBee hub is required for integration into a smart home system (not included).

L24CSH
2-pole, Smart Home controller with 9-fold distributor for connection to power supply unit L24 NT ..

CHANGE DOMO, ZBLL (NEW INTERIOR PULLOUT LIGHTING)

As part of the system concept: our ZBLL interior pullout lighting and our DOMO railing systems are now also included in our L24 system. This means that almost all lighting products are integrated in the L24 system. With ZBLL, only the light colour can be changed by using the L24SK2 switch cable. ZBI interior pullout lighting becomes ZBLL DOMO railing NSMLED becomes NSMLLD

SINKS AND TAPS



Single bowl stainless steel FRANKE SKX 611-100 LB

FRANKE

The following FRANKE sinks are being launched:

Sinks:
FRANKE SKX 611-100 LB
FRANKE FLN 611-78/44



FRANKE

The following FRANKE taps are being launched:

Tap colour extension Tap Centro FRANKE chrome



Single bowl Fraganit FRANKE MRG 210-52

FRANKE

The following FRANKE sinks are being launched:

Sinks:
FRANKE MRG 210-72
FRANKE MRG 210-52
FRANKE MRG 210-37



BLANCO

The following BLANCO taps are being launched:

Taps:
BLANCO Linus-S
612 satin dark steel
613 satin platinum

BLANCO Linus
612 satin dark steel
613 satin platinum

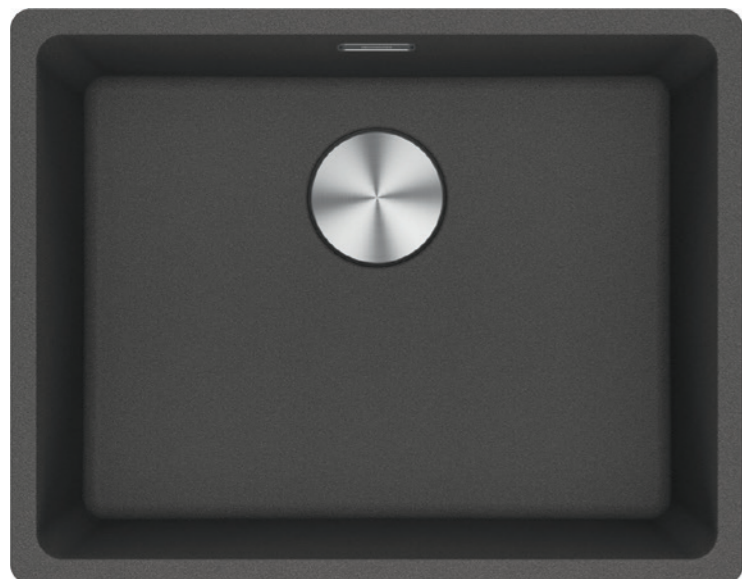

FRANKE

With the colour 648 grey slate, we are extending the colour world of the FRANKE Fraganit sinks with another classy colour in the dark grey range. It is somewhere between the existing tones 636 stone grey and 643 onyx.



BLANCO

The following BLANCO taps are being launched:

Taps:
BLANCO Culina S II Min
613 satin platinum
612 satin dark steel

HANDLES



Metal bow handle

520.405 stainless steel
521.XXX powder-coated
Handle position: A/B/D

Metal bow handle

522.405 stainless steel
523.XXX powder-coated
Handle position: D



Metal bar handle

670.405 stainless steel
671.XXX powder-coated
Handle position: vertical (B)
Only tall units possible



Metal bow handle

535.306 steel
Handle position: A/B/D



Metal knob

165.306 steel
Handle position: A/B/D



Grip rail profile

661.319 alpine natural oak
661.320 walnut natural
Handle position: in acc. with KYOTO

DISCONTINUATION

This page is an overview of the most important articles being discontinued in 2024/25.

PROGRAMMES AND COLOURS

222 SYNTHIA
KI 229v fjord oak

254 TOCCO
K 282 alpine grey

422 SYNTHIA-A
KI 229v fjord oak

454 TOCCO-A
K 282 alpine grey

722 SYNTHIA-C
KI 229v fjord oak

754 TOCCO-C
K 282 alpine grey

ACCESSORY SURROUND

K 282 alpine grey
KG 282 alpine grey
KH 229 fjord oak

CARCASE EDGE COLOUR

KH 229 fjord oak

WORKTOPS

KH 229 fjord oak Laminate worktop
AP KP1*KPW Compact worktop with a white core

SINKS AND TAPS

Single bowl stainless steel FRANKE EFX 614-78
Drip tray FRANKE 112.0204.360

HANDLES

597.405 Metal bow handle
396.404 Metal bow handle

UNITS

TMWU61 Washing machine support (change to 62 cm width)
HFEA*E Fold-away door system (change to handle-less variant)
O**GW Wall unit with spice rack

LIGHTING

ZBI* Interior pullout lighting ZBI*US Interior pullout lighting
S24NTV40 LED power supply unit 24 Volt system S24NTV75 LED power supply unit 24 Volt system ZBIS24NT75US LED interior pullout lighting USA S24VT4 distributor 24 Volt system
ZBIS24VTUS distributor 24 Volt system S24VK4 extension cable 24 Volt system

ACCESSORIES

DRGW12C Spice rack 4 rows
DRGW18C Spice rack 4 rows

MISCELLANEOUS

WAN10 Wall contour blender WAN20 Wall contour blender WAN40 Wall contour blender

PUBLICATION DETAILS

LEICHT Küchen AG
Postfach 60
73548 Waldstetten
Germany Phone +49 | 7171 | 402-0
info@leicht.com www.leicht.com

LEICHT reserves the right to make technical changes. Colour deviations are possible due to printing technology.

