

# Concrete Masonry

## Site Practice and Workmanship Guide



Concrete New Zealand

July 2020



## Acknowledgements

*[inside cover – intentionally left blank]*

## **Acknowledgements**

This Guide was prepared by:  
Ralf Kessel, Architect (NZRAB), Concrete NZ

With review assistance of:  
Bowers Brothers Concrete  
Mitchell Concrete  
Firth Industries  
The Block Shop  
Viblock

## **Disclaimer**

All information provided in this document is guidance only and in no way replaces the services of professional consultants. No liability can be accepted by Concrete NZ for its use.

## **Copyright**

© July 2020 Concrete NZ  
PO Box 448, Wellington 6140, New Zealand  
Phone 644 499 8820, email [admin@concretenz.org.nz](mailto:admin@concretenz.org.nz), website [www.concretenz.org.nz](http://www.concretenz.org.nz)

Extracts from NZS 4210:2001 and NZS 4229:2013 have been provided by Standards New Zealand under licence LN001372.

Except where the Copyright Act allows, no part of this publication may be reproduced, stored in any retrieval system in any form, or transmitted by any means, without the prior permission in writing of Concrete NZ.

ISBN: 978-0-908956-73-9  
ISBN (online): 978-0-908956-74-6

### ***Images:***

*with kind permission of Bowers Brothers Concrete and Firth Industries*

## About this guide

This is a guide to good site practice and workmanship for concrete masonry. It is intended for use by all members of the building team, including site supervisors and brick and block layers.

This guide:

- covers the key points for preparing and carrying out masonry work onsite
- includes extracts from relevant Standards and Codes of Practice for easy reference
- provides a handy action checklist.

High levels of workmanship and site practice should result in durable brick and blockwork that has a consistent appearance and needs little or no maintenance during its design life.

Units, mortar, grout, rebar and other ancillary components such as beams and columns must also be designed and specified in accordance with the New Zealand Building Code and relevant Standards.

If you need more advice, concrete masonry manufacturers have a vested interest in the achievement of successful masonry work and can help with all aspects of workmanship and site practice.

## Quick checklist for concrete masonry construction

This checklist summarises the key points discussed in this guide. You can copy and print it for easy reference.

<b>Before you start</b>	✓
Order early from the manufacturer; check site access to a suitable storage area	
Check risks are eliminated/minimised (Refer to Worksafe New Zealand's website at <a href="http://www.worksafe.govt.nz">www.worksafe.govt.nz</a> for more information)	
Check relevant Standards and Codes of Practice	
Obtain agreement by all parties if a reference panel is required	
<b>Getting ready</b>	✓
Check the delivery – make sure units are the correct type, number and quality	
Site storage – provide adequate protection for materials onsite	
Take suitable precautions if air temperature is likely to be below 5° C or above 25° C	
<b>Set to work</b>	✓
Make sure mortar is made to specifications	
Are the units laid correctly and onto a clean substrate, and are the joints tooled to the manufacturer's requirements?	
Are rebars installed to specifications and tolerances?	
Does the grout have the correct properties, strength, admixtures and workability?	
Are control joints placed at required locations?	
Are the walls sealed for weathertightness and to mitigate against efflorescence?	
<b>Keep checking</b>	✓
Are the walls within tolerances of NZS 4210, Table 2.2?	
Is the blockwork protected when work is not proceeding?	
Are the walls propped during construction against wind and earthquake loads?	

## Contents of this guide

### Before you start

p7

Check your supplies and the site  
Health and safety precautions  
Relevant Standards and Codes of Practice  
Construct a reference panel if required



### Getting ready

p10

Check the delivery  
Site storage  
What's the weather?

### Set to work

p12

Making the mortar  
Laying the units and tooling  
Installing rebars  
Grouting  
Placing control joints in the grout  
Final weather seals



### Keep checking

p23

Check wall tolerances  
Protect blockwork while not working  
Temporary propping

### Resources

p26



## Before you start

### Check your supplies and the site

One of your first tasks when starting a new masonry project should be to consult with the manufacturer, involving them as appropriate in pre-contract meetings and discussions. You will need an accurate delivery schedule for bulk orders to help suppliers plan availability and delivery. In particular, any specially shaped units may be subject to lead times – early consultation with the manufacturer is vital to avoid any programme delays.



Another early planning step should be to earmark a suitable storage area onsite. This area should be firm, level and well drained. It should be large enough to store the amount of material being delivered and also have some contingency space.

Your proposed storage area should be easy to access for the expected size of delivery vehicle. Also consider whether the material stored there will be an obstacle and/or obstruct site works and other vehicle movements. Avoiding this also means the material is less likely to be at risk of soiling from passing vehicles or adjacent site operations.

### Health and safety precautions

Before starting work, make sure you are clear what health and safety precautions need to be taken. You can use a risk matrix to identify the risks and also what precautions can be taken to eliminate or reduce these.

Once work starts, you will need to review work on an ongoing basis to identify any new risks that need to be managed.

*Always ensure your health and safety! Protect yourself by use of a harness or suitable rope system when working at height.*



## Dust control measures when cutting or grinding blocks

Protect yourself and your co-workers from potential harm from dust and micro silica released when cutting or grinding concrete blocks. Use tools which provide water to the blade system and an on-tool extraction collector. To remove dust use H-class HEPA-filtered vacuum cleaners in accordance with Standard AS/NZS 60335-2-69<sup>1</sup>. Seal dust waste bags and place them in the correct waste container.

### Alert:

Worksafe New Zealand now enforces dust control in the immediate area when cutting blocks. Fines are being imposed if appropriate steps are not taken to protect others working onsite. Go to [www.worksafe.govt.nz](http://www.worksafe.govt.nz) for more information and guidance on what is required.

## Relevant Standards and Codes of Practice

It is important for brick and block layers to be familiar with the performance requirements of the New Zealand Building Code (refer to [www.building.govt.nz](http://www.building.govt.nz) for more about Building Code compliance) and the content of current New Zealand Standards and guidance related to masonry work, which provide ways to meet these requirements. Key documents include:

- CCANZ CP 01 - Code of Practice for weathertight concrete and concrete masonry construction
- NZS 4210:2001 Masonry construction: Materials and workmanship
- NZS 4229:2013 Concrete masonry buildings not requiring specific engineering design
- NZS 4230:2004 Design of reinforced concrete masonry structures (used by engineers)
- NZS 3104:2003 Specification for concrete production (provides an understanding of the properties of mortar, grout and concrete in general).

These documents are available at Building CodeHub (<https://codehub.building.govt.nz>) or from Standards New Zealand ([www.standards.govt.nz](http://www.standards.govt.nz)).

### Also see:

- NZS 3101.1&2:2006, Amendment No. 3, 2017 - Concrete structures standard
- NZS 3103:1991 Specification for sands for mortars and plasters
- NZS 3109:1997 Concrete construction
- NZS 3121:2015 Water and aggregate for concrete
- NZS 3124:1987 Specification for concrete construction for minor works
- AS/NZS 4671:2019 Steel for the reinforcement of concrete

---

<sup>1</sup> AS/NZS 60335-2-69:2017 – Household and similar electrical appliances – Safety. Part 2.69: Particular requirements for wet and dry vacuum cleaners, including power brush, for commercial use (IEC 60335-2-69 Ed 5:2016, MOD)

## Construct a reference panel if required

Constructing a reference panel of brick or blockwork onsite is a good idea before work starts, as it provides a benchmark if any issues arise. This should be agreed by the client and all other relevant parties (e.g. the engineer and architect). In general terms, it's also best to sort out any uncertainties with the parties before starting/ continuing the job.

Site reference panels are especially important for concrete brick veneer. They provide the opportunity to identify the inherent characteristics of the concrete brick such as colour variance, shape, size, texture, and any chips. They also illustrate the mortar joint colour and shape. These panels are also important if architectural masonry has been requested and design requirements for the appearance have been specified. On masonry end blocks there could also be "core bar" cracks. A reference panel sets the general standard of workmanship and level of expectation that can be reasonably achieved by the block layer given the specified material.

The reference panel shall show at least 1 m<sup>2</sup> of block/ veneer face. Choose a stable and suitable site for constructing the panel which does not obstruct any works or storage areas. Also consider the access arrangements and ensure that the delivery vehicle can be safely manoeuvred to the desired delivery point.



*A reference or sample panel should be agreed by the client and all other relevant parties.*

## Getting ready

### Check the delivery

Check the type and quantity of material that is delivered onsite against the design, drawings, specifications and agreements.

It's a good idea to select a number of concrete blocks at random from the delivery.

Check their appearance is reasonably consistent with the site reference panel.



If you are not sure whether they are acceptable, ask the relevant parties as soon as possible.

### Site storage

As concrete blocks and bricks can be susceptible to chipping, always take care to place packs carefully with the forklift and avoid allowing any distortion of the pack shape to occur.

Bricks and blocks must be stored with a cover and protected from bad weather. Excessively wet or saturated blocks are difficult to lay and may risk causing efflorescence, lime leaching and mortar colour variation.

### What's the weather?

If the air temperature is below 5° C or above 25° C you will need to take some extra steps if you want to start work.

Generally, masonry construction should not be carried out when it is below about 5° C without taking precautions such as:

- heating the water used for mixing mortar
- not using any frozen materials or materials containing ice
- protecting masonry for at least 24 hours after it has been laid – you can use covers, blankets, heated enclosures or similar to make sure the mortar can gain strength without freezing or suffering any harmful effects from cold winds.

If the air temperature is more than 25° C you will also need to take precautions, such as:

- lightly dampening masonry units before laying
- keeping the mortar moist – mortar must not be spread on the wall more than two unit lengths ahead of the units being placed
- preventing the mortar from drying so rapidly that it cannot cure properly – you can do this by applying a very light fog spray several times during the first 24 hours after the blocks are laid, or by taking other protective measures over the same period.



## Set to work

### Making the mortar

Make sure your mortar is made to the specifications for the project and that its constituents are clean and accurately gauged. Mortar mixes are typically specified by volume ratios – ingredients differ, so be sure to use the correct mix for the application.

Mortar generally requires a compressive strength of 12.5 MPa unless otherwise specified.



Table 2.1 of NZS 4210 Masonry construction: Materials and workmanship shows the mixtures for durability classes M2 – M4.

**NZS 4210 Table 2.1 – Mortar mix composition using parts by volume using hydrated lime**

Durability	Cement	Hydrated lime	Sand
M4 [Exposed/Coastal]	1	0 - 0.25	3
M3 [Exterior/Inland]	1	0.5	4.5
M2 [Interior]	1	1	6

#### Comment from NZS 4210:

**C2.2.2.1** *The workability of mortars is significantly affected by sand grading and particle shape. For the majority of mortars it is likely that the use of an admixture or hydrated lime will be necessary to produce the desired workability. Admixture dosage should strictly follow the manufacturer's instructions since significant loss of strength and bond can occur through over dosage.*

The following table gives tips for mixing mortar.

<b>Mortar mixing tips</b>	
<b>Safety first</b>	<ul style="list-style-type: none"> <li>• Always wear eye protection and waterproof gloves when mixing mortar.</li> </ul>
<b>Preparing the ingredients</b>	<ul style="list-style-type: none"> <li>• Use a dry bucket to measure out the materials.</li> <li>• Use cement from unopened bags – opened cement bags tend to absorb environmental humidity, which changes the water percentage of the mortar mix and can reduce its strength.</li> <li>• If you are mixing by hand, prepare a mixing container with a flat, solid surface base and tall sides.</li> <li>• Pre-wet the mixing container before filling it with fresh mortar.</li> </ul>
<b>Mixing the mortar</b>	<ul style="list-style-type: none"> <li>• Add the masonry cement, additives and sand in the appropriate amounts to your mixing container, then add water on top of the dry ingredients.</li> <li>• If you are mixing by hand, fold the mortar mix from the bottom into the water and keep mixing until the water is mixed in. Next, add more water and keep mixing. Keep adding water until the mortar attains a smooth consistency.</li> <li>• Stop mixing when the mortar is wet enough to slip easily off the shovel but holds its shape if you make a hollow in the mix. Mortar has attained the correct viscosity when you can make a few ledges in the mortar mix and these ledges stand up.</li> <li>• Mix mortar for not less than three minutes and not more than five minutes after the last materials have been introduced into the mixer or tub.</li> </ul>
<b>What to watch for</b>	<ul style="list-style-type: none"> <li>• It is important to understand that once the mix starts to set it cannot be re-mixed because this will reduce the mortar's strength. Also, if too much water is added to the mix this will affect the mortar's chemical composition, reducing its strength and potentially causing problems in the future.</li> <li>• Mortar, like concrete, is only good for 90 minutes. After that time you will need to discard it because it starts to lose some of its characteristics and workability.</li> </ul>

#### **More mortar tips:**

Also see The Brick and Blocklayers Federation 'Veneer best practice guide' at [www.bbfnz.co.nz/bricks-and-blocks/masonry-brick-veneer-best-practice-guide](http://www.bbfnz.co.nz/bricks-and-blocks/masonry-brick-veneer-best-practice-guide)

## Preventing mortar colour variation

Prevent variations in mortar colour by controlling the exposure of mortar to any additional water until it has set. Ways to achieve this include, but are not limited to, the following:

- Consider humidity levels when laying. Aim to lay the areas of the build that will get the afternoon sun in the afternoon.
- Make sure that masonry units are not carrying any additional water by protecting them from exposure to the elements or to water on or in the ground.
- Ensure the sand and cement ratios are consistent. This is more easily achieved if you are using bagged mortar. If batch mixing, ensure that you are using a consistent measuring device for the sand and cement (i.e. use buckets not shovels).
- Cover any unfinished work when you stop for the day or for any extended period.
- Check that the mortar joint is “thumbprint” hard before tooling.
- Ensure that the jointers you are using are made of a consistent material. For example, steel jointers can cause mortar to dry darker than plastic coated jointers.
- Avoid over-tooling (aggressive or elongated).
- Avoid retempering coloured mortar, especially when using dark colours.
- When the work is complete, ensure that it is covered for at least six to eight hours to allow the mortar joints to harden and completely seal.

## Laying the units and tooling

Concrete blocks should not be laid when they are saturated as their subsequent drying out will result in a considerable amount of shrinkage movement. This will cause cracks in joints and, possibly, in the units themselves.

Before laying masonry units, the concrete substrate shall be clean and free from contaminants, loose aggregate

and any other material that could reduce the bond between the units and the base.



Laying of masonry units shall be in accordance with NZS 4210. All masonry units shall be laid in mortar in courses, true to line, plumb, and level to the tolerances of NZS 4210, unless otherwise specified.

Mortar must cover the entire face shell width of the blocks. The mortar joints shall be compressed by tooling in accordance with NZS 4210 and Detail 70 of CCANZ CP 01. The mortar joint shall be tooled after the initial water loss, once the mortar is thumbnail hard.

## Installing rebars

Reinforcement requirements for concrete masonry walls are given in NZS 4210 paragraph 2.6. Reinforcement shall be detailed, bent and placed in accordance with NZS 3109, NZS 3124 or NZS 4229, except where subject to specific engineering design.

Details of standard bends are given in NZS 4210, Appendix 2.D. Table 2.E1 of NZS 4210 (reproduced on the next page) provides the minimum steel coverage for the various exposure zones to meet the requirements of Building Code Clause B2 Durability.

- Vertical bars shall be securely held in position at the top of the wall, and placed at intervals not exceeding 1.2 m for 10 mm bars; 2.4 m for 12 mm bars; or 3.6 m for 16 mm or larger bars.
- Horizontal bars are required to be in grouted cells and shall be at least 25 mm above or below a mortar joint and fully embedded in grout. Horizontal bars shall be positively held in position by tying the bar to the vertical reinforcement or by the use of specially designed units, steel spacers or links.



NZS 4210 Table 2.E1 – Masonry durability requirements

Exposure categories		Durability requirements			
NZS 3604 <sup>2</sup> zones	NZS 3101 zones (Note 1)	Masonry units (Note 2)	Mortar (Note 3)	Classification built in components (Note 4)	Minimum cover to reinforcement (Note 5)
Seaspray	B2	Exposed	M4	R4	30 (60)
1 & 4	B1	General purpose	M4	R3	20 (50)
2 & 3	A2	Protected	M3	R3	15 (45)
Closed interior	A1	Protected	M2	R1	5 (35)
Geothermal hotspot	U	Exposed	M4	R5	Specific engineering design consideration

## NOTE –

- (1) The NZS 3101 zones shall be as defined in section 5 of that Standard.
- (2) These classifications are defined in AS/NZS 4456.10<sup>3</sup> for resistance to salt attack. The requirement is not needed for concrete masonry products.
- (3) The requirements of the mortar to meet the classifications nominated in the table are given in 2.2.2.1 of this Standard.
- (4) The classifications are defined in AS/NZS 2699: Part 1 Wall Ties, Part 2 Connectors and Accessories, Part 3 Lintel and shelf angles. A protection specification is given for the component which a manufacturer must meet and label the component to identify the level of corrosion protection.
- (5) The cover is measured from the inside of the cell face of the unit. The figures in brackets are the approximate total cover to the outside face of the wall assuming a face shell thickness of 30 mm. Reinforcements shall be restrained so that the minimum covers are maintained during construction. Retaining walls shall be classed as B2 as specified in NZS 3101.
- (6) When weatherproofed to the requirements of 2.21.2.2 – 2.21.2.5, Exposure Categories 1, 2, 3 & 4 (NZS 3604) or B1 & A2 (NZS 3103) can be reduced to “Closed interior” or “A1”. When waterproofed to the requirements of 2.21.2.1 all exposure categories can be reduced to “Closed interior” or “A1”.

<sup>2</sup> NZS 3604:2011 Timber-framed buildings

<sup>3</sup> AS/NZS 4456.10:2003 Masonry units and segmental pavers and flags - Methods of test Determining resistance to salt attack

Typical rebar layout around windows is shown in NZS 4229 Figure 8.1 (reproduced below). However, this is indicative only: layout may vary, depending on structural requirements.

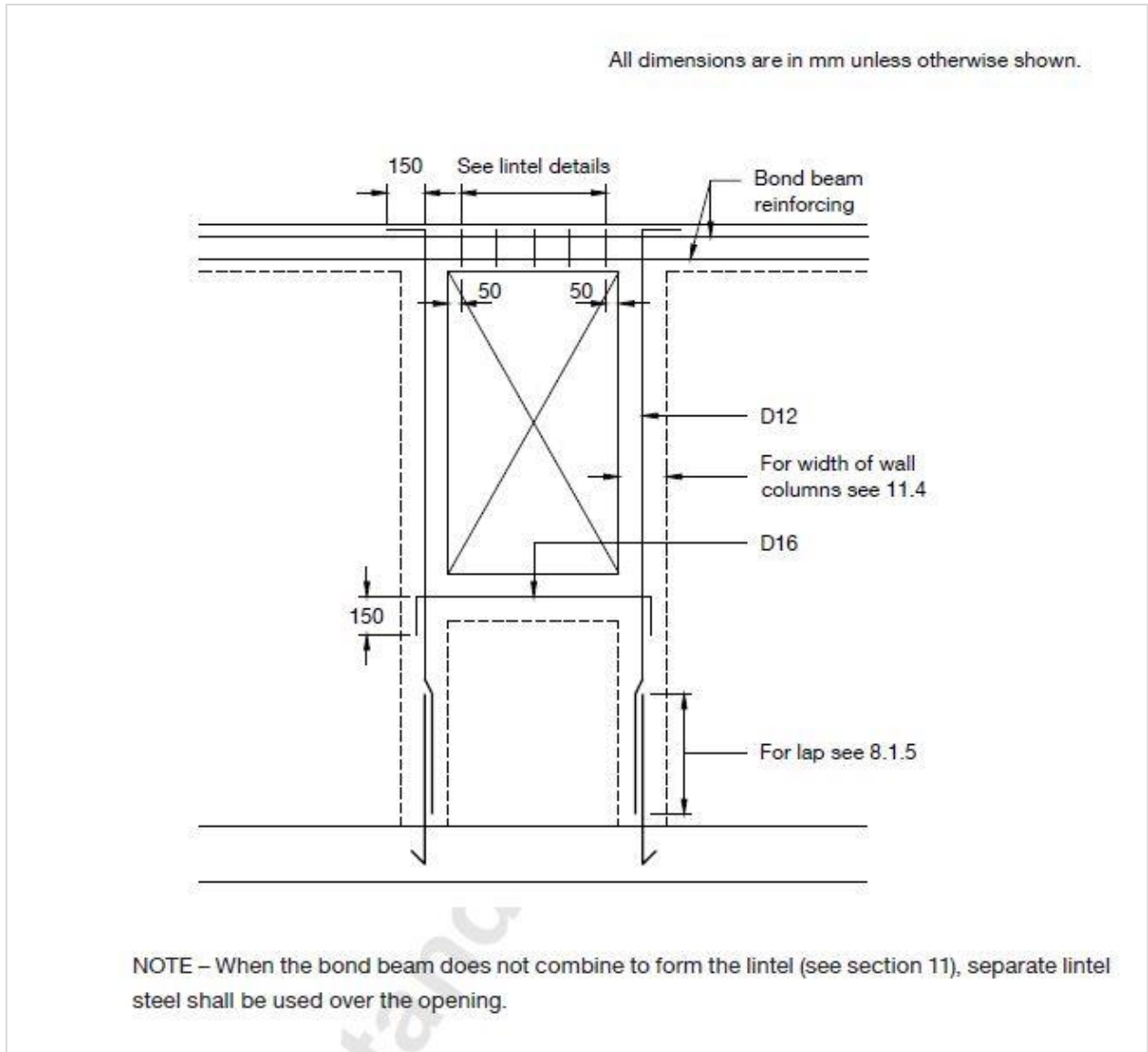

**NZS 4229 Figure 8.1 – Reinforcement above and below openings**

## Grouting

Before grouting, check that the works comply with the drawings and specifications. Also check:

- the cells are clean for grouting
- reinforcement is correctly positioned and tied
- all clean out holes and positions that would cause the loss of grout have been sealed.

Masonry grout generally requires a compressive strength of 17.5 MPa (unless otherwise specified). The grout must fill the cells, provide the specified compressive strength, and bond the reinforcing steel to the masonry units.

To meet these criteria the flowability, aggregate size and proportions of a grout mix must be compatible with the application. Fine and coarse aggregates for concrete grout shall comply with NZS 3121. An expansive admixture is generally used to make sure the grout reaches into every corner of the cell.

Key steps for applying this grout are as follows:

Applying high lift grouting	
<b>Step 1</b>	Clean out the grout space and remove all debris and loose material from the construction joint.
<b>Step 2</b>	Grout the wall in a semi-continuous operation to the top.
<b>Step 3</b>	Consolidate with a vibrator or by rodding (see note below) as filling work proceeds to the top.
<b>Step 4</b>	After waiting for expansion, trowel down and re-compact the top surface of the expanded grout. An alternative method is to place a weighted board on top of the wall to contain the expansion.

### What NZS 4210 says:

**2.14.2.2** Consolidation shall be carried out by mechanical immersion vibration or rodding with a solid bar or rod of minimum dimension 16 mm until no settlement of top surface occurs.

### More grouting tips:

Also refer to section 4.3 of the 'New Zealand Concrete Masonry Manual', available at [https://concretenz.org.nz/page/masonry\\_manual](https://concretenz.org.nz/page/masonry_manual)

## Placing control joints in the grout

While grout cures, water escapes and reduces the grout's volume so cracks occur. These cracks cannot be prevented, but their location can be determined through the placement of control joints.

Control joints are continuous vertical joints at places where stresses due to grout shrinkage might concentrate. Control joints are also required at:

- major changes in wall height
- changes in wall thickness
- chases or recesses for services
- wall intersections
- return angles in L, T and U shaped footprints
- one or both sides of any openings.

The following figures show typical examples of a wall control joint and a bond beam control joint.

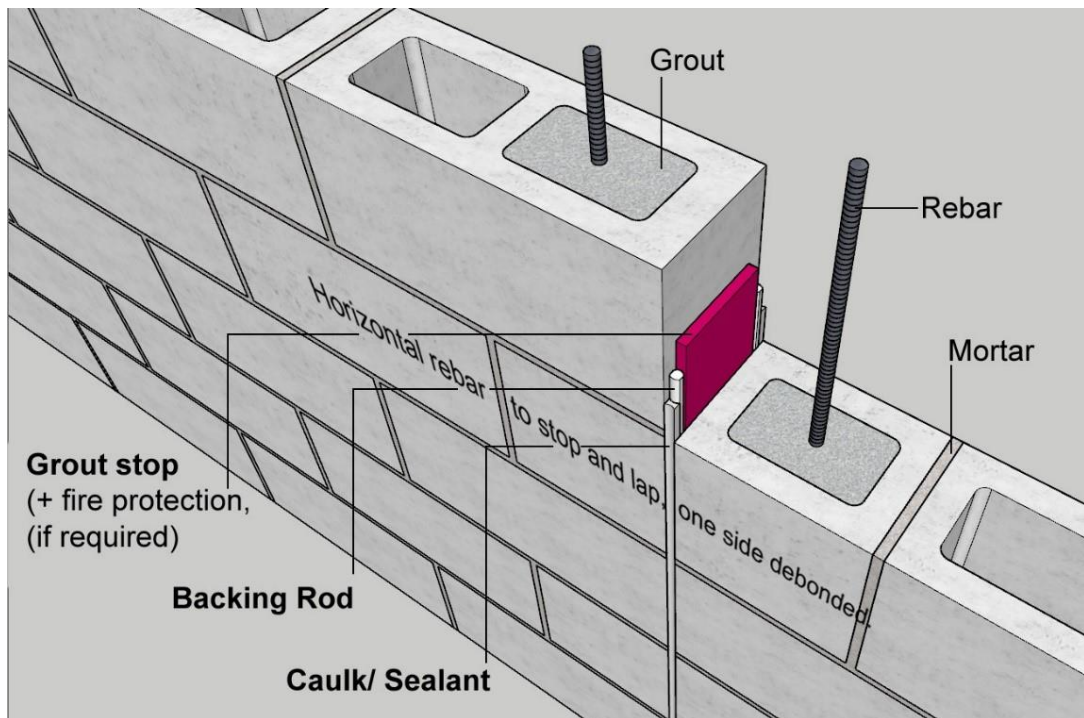

*Control joint example, wall area*

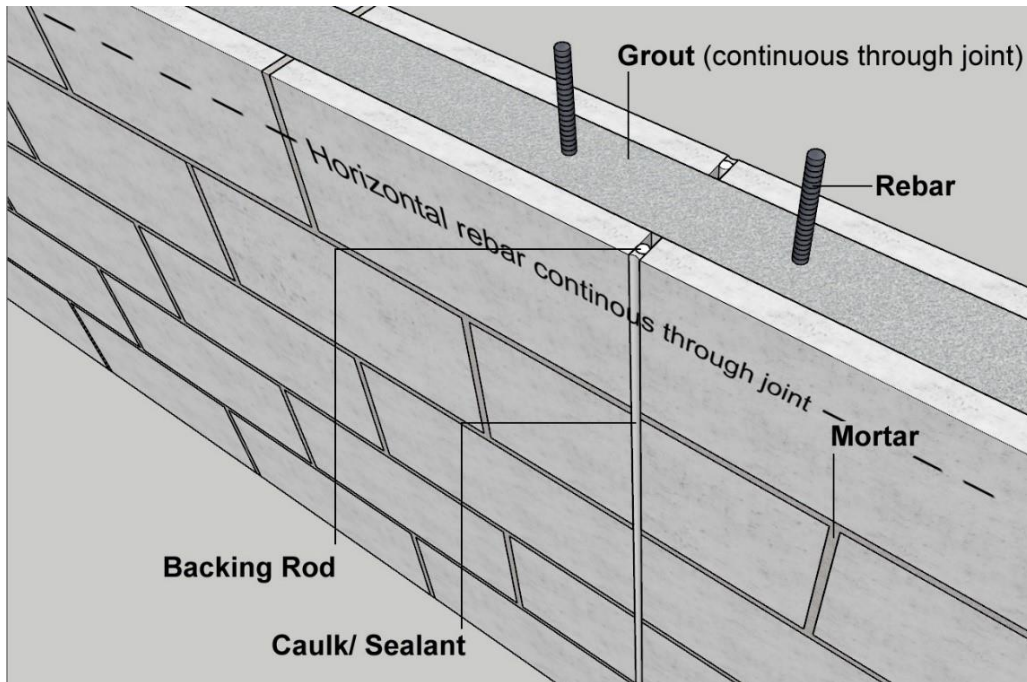

**Control joint example, at bond beam level**

The spacing of control joints shall not exceed 6 m and they shall be constructed in every respect to the details and requirements of NZS 4229 and NZS 4210, unless otherwise specified on the drawings. Ideally, no reinforcement should pass through the control joint but this is often impractical in New Zealand because of seismic requirements. It is usual to debond any reinforcement passing through the control joint for at least 400 mm on one side of this joint (see NZS 4229 Figure 12.2, reproduced below). However, this is not the case for bond beam and lintel reinforcement, where the reinforcement continues uninterrupted and is bonded to both sides.

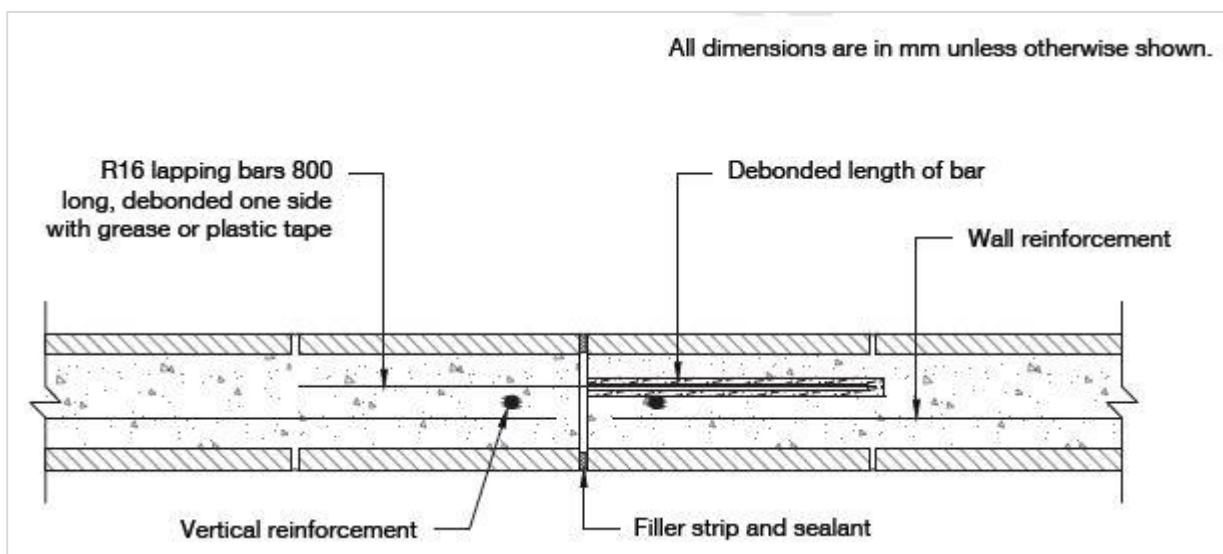

**NZS 4229 Figure 12.2 – Control joint detail for solid-filled walls and partially filled walls where horizontal bars are placed between floors but not bond beams**

The Concrete Masonry Manual (CCM) Figure 3 below shows both control joints: the hatched area shows bond beam reinforcement passing through, whereas the joint within the lower course shows the reinforcement lapping and debonding to one side.

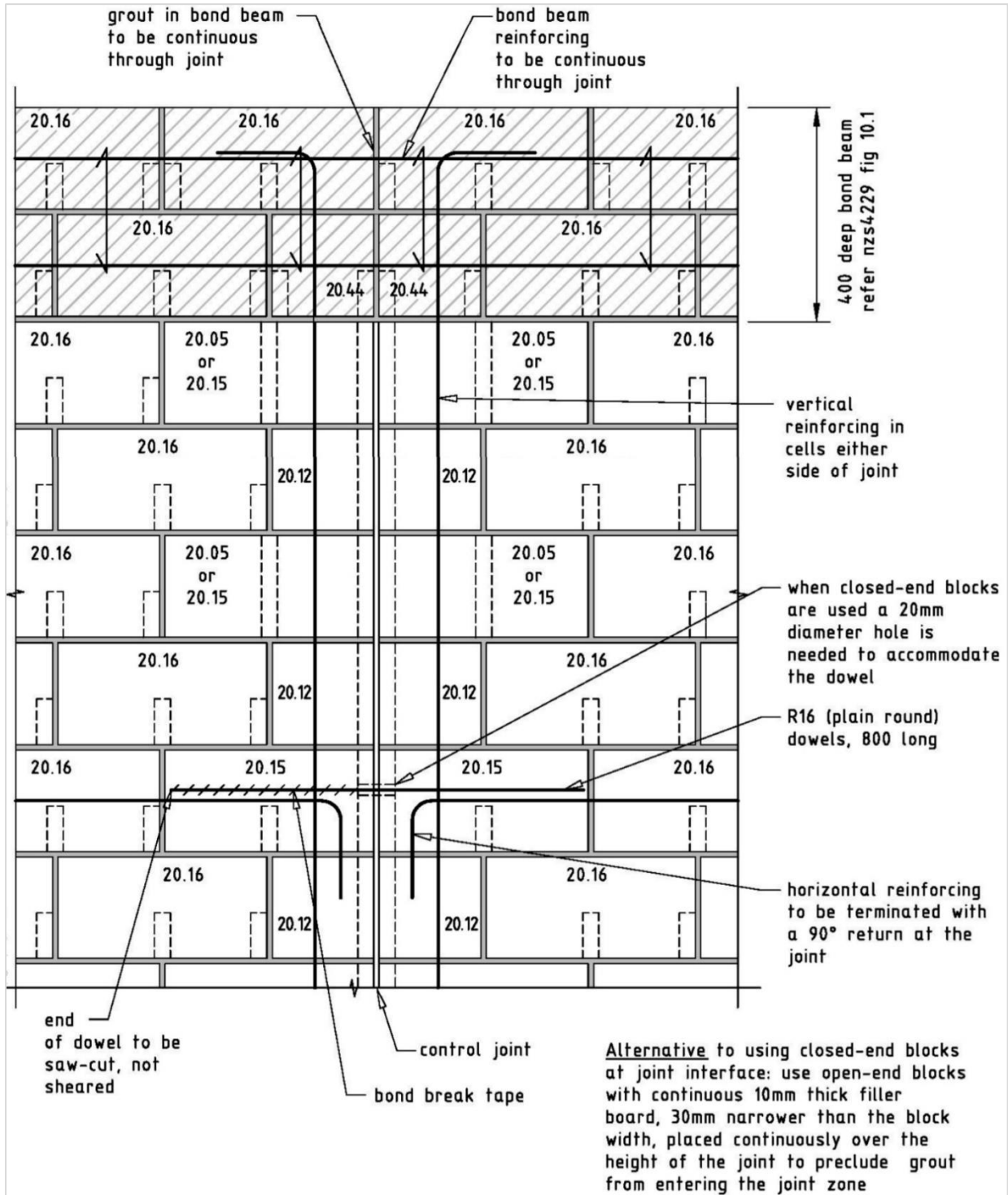

**CMM, Figure 3 – Control joint elevation**

## Final weather seals

Masonry walls exposed to the weather will require some form of protection so they are sufficiently weathertight to meet the requirements of Building Code Clause E2 External moisture. This can be done in accordance with CCANZ CP 01 section 4: this Code of Practice is cited in Acceptable Solution E2/AS3 (a means of compliance with Clause E2). The walls can be sealed with clear or pigmented coatings, plastered, or receive an exterior insulation and finish system (EIFS).

This requirement does not apply to brick veneer installed in front of a ventilated cavity, as brick veneer is deemed to be weathertight protection for masonry structures when installed as per CCANZ CP 01, section 4.6.

If efflorescence is a concern, applying a clear sealer or pigmented coating is recommended: this will absorb water across a masonry surface and also prevent efflorescence from recurring.



*A clear coating weather seal provides a matt finish to this wall and helps prevent efflorescence.*

### More tips:

See Firth's publication 'Architectural Masonry – Best practice guide for specifiers + installers', at [www.firth.co.nz/assets/Uploads/TechnicalDocuments/AM-Best-Practice-Guide-June-2018.pdf](http://www.firth.co.nz/assets/Uploads/TechnicalDocuments/AM-Best-Practice-Guide-June-2018.pdf)

For more about Acceptable Solutions and other ways to comply with the Building Code go to [www.building.govt.nz](http://www.building.govt.nz)

## Keep checking

### Check wall tolerances

Wall straightness should be checked throughout construction. NZS 4210 Table 2.2 (reproduced below) provides acceptable tolerances.

NZS 4210 Table 2.2 – Maximum tolerances	
Item	Tolerances
Deviation from the position shown on plan for a building more than one storey in height	15mm
Deviation from vertical within a storey	10 mm per 3 m of height
Deviation from vertical in total height of building	20 mm
Relative vertical displacement between masonry courses	
(a) Nominated fair face (one side only)	3mm
(b) Structural face	5mm
Relative displacement between loadbearing walls in adjacent storeys intended to be in vertical alignment	5 mm
Deviation from line in plan	
(a) In any length up to 10 m	5 mm
(b) In any length over 10 m	10 mm total
Deviation of bed joint from horizontal	
(a) In any length up to 10 m	5 mm
(b) In any length over 10 m	10 mm total
Average thickness of bed joint, cross joint, or perpend	$\pm 3$ mm on thickness specified
NOTE – Tolerances shall not breach minimum cavity widths.	

## Protect blockwork while not working

Brickwork must be kept clean and protected from rainfall, contamination and snow. During breaks in construction, take particular care to cover the top course of block and brickwork with waterproof sheeting so it is adequately protected from bad weather.



Make sure that no mortar smearing or splashing occurs as the work proceeds. Staining of brickwork often comes from excessive wetting or saturation of recently built brickwork.

If overnight frost is expected before the mortar has fully set, it shall be protected with an insulating layer underneath the waterproof sheet.

## Temporary propping

Masonry work requires temporary propping to resist wind, earthquake and other lateral loads until it can support itself without any distress to the components. Typically, a wall over one metre in height is at significant risk. An ungrouted wall is very susceptible to failure from strong winds.



**What NZS 4210 says:**

**2.17 Bracing during construction**

Temporary bracing shall be provided to masonry where necessary to resist lateral loads during construction.

**C2.17**

*Unfilled blockwork 190mm thick, 1m high becomes unstable when subjected to a wind gust of velocity above about 90 km/h, while a similar wall 2.4 m high becomes unstable at a gust velocity above about 60 km/h. Thinner walls become unstable at lower gust velocities.*

Propping of walls during construction is needed at 3 m centres for at least five to seven days after erection.



## Resources

The following publications provide further guidance:

New Zealand Concrete Masonry Association 'New Zealand Concrete Masonry Manual'

[https://concretenz.org.nz/page/masonry\\_manual](https://concretenz.org.nz/page/masonry_manual)

Brick and Blocklayers Federation of New Zealand (BBFNZ) 'Masonry (Brick) Veneer Best Practice Guide'

[www.bbfz.co.nz/bricks-and-blocks/masonry-brick-veneer-best-practice-guide](http://www.bbfz.co.nz/bricks-and-blocks/masonry-brick-veneer-best-practice-guide)

NZS 4210:2001 Masonry construction: Materials and workmanship

<https://www.standards.govt.nz/sponsored-standards/building-standards/nzs4210/>

NZS 4229:2013 Concrete masonry buildings not requiring specific engineering design

<https://www.standards.govt.nz/assets/Publication-files/BSP/NZS4229-2013.pdf>

Firth 'Architectural Masonry – Best practice guide for specifiers + installers'

[www.firth.co.nz/assets/Uploads/TechnicalDocuments/AM-Best-Practice-Guide-June-2018.pdf](http://www.firth.co.nz/assets/Uploads/TechnicalDocuments/AM-Best-Practice-Guide-June-2018.pdf)

Firth 'Rapidstak™ Mortarless Masonry'

[www.firth.co.nz/assets/Uploads/TechnicalDocuments/FIR0745-Rapidstak-bro-16pg.pdf](http://www.firth.co.nz/assets/Uploads/TechnicalDocuments/FIR0745-Rapidstak-bro-16pg.pdf)

New Zealand Masonry Trades Association (NZMTA), Trade Support Documents

<https://nzmta.com> (members only)

*[inside cover – intentionally left blank]*

