

# YOUR HEALTH OUR PRIORITY

Monitor Arm Solutions



Work Better. Feel Better.™



# WE ARE FELLOWES

---

For more than 100 years, Fellowes® has been helping people be the best they can be while at work. **More productive. More efficient. Happier. Healthier.**

## What we stand for.

We are the Fellowes family. We believe the workspace should be an optimal environment for a personal pursuit of meaningful work. We are bonded by a century long commitment to creating workspace solutions that communicate care and respect, and we believe that with the right tools, everyone has the ability to fully harness their potential.

**Everything that carries the Fellowes name is a promise of quality, performance, innovation and outstanding customer service.**





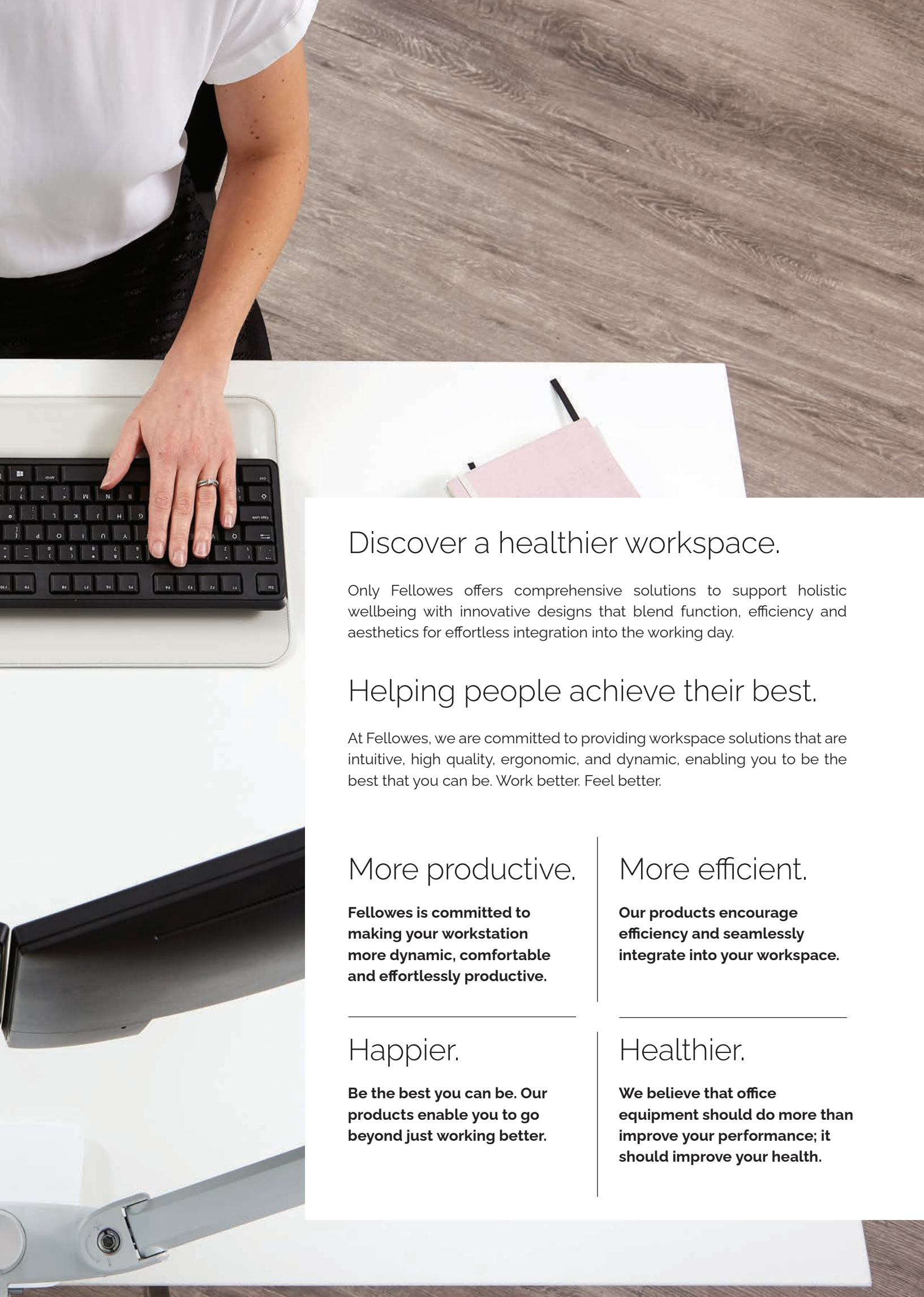

## Discover a healthier workspace.

Only Fellowes offers comprehensive solutions to support holistic wellbeing with innovative designs that blend function, efficiency and aesthetics for effortless integration into the working day.

## Helping people achieve their best.

At Fellowes, we are committed to providing workspace solutions that are intuitive, high quality, ergonomic, and dynamic, enabling you to be the best that you can be. Work better. Feel better.

### More productive.

**Fellowes is committed to making your workstation more dynamic, comfortable and effortlessly productive.**

### More efficient.

**Our products encourage efficiency and seamlessly integrate into your workspace.**

### Happier.

**Be the best you can be. Our products enable you to go beyond just working better.**

### Healthier.

**We believe that office equipment should do more than improve your performance; it should improve your health.**

# RAISE YOUR VIEW FOR A HEALTHY OUTLOOK

Using a monitor arm means that you can set your screen to be the exact height and angle to improve your health when working. Whether sitting or standing whilst using a computer, it will improve your ergonomic posture by preventing leaning forward or tilting the head, to avoid back, neck and eye strain.

With ever shrinking office space, using a monitor arm also means you can free up valuable workspace. Maximise your work environment and in-line desk area through elevating your screen with clear space underneath, to become more organised and productive. In addition research shows that introducing a second monitor can increase productivity further, by up to 30%\* and reduce errors up to 33%!\*\*

Fellowes 100-year wealth of research and product development in the office workspace has engineered a monitor arm and accessories range, designed to allow effortless adjustment for full workspace flexibility, with configurations and added features to suit all individual work styles.

\*<http://www.nytimes.com/2006/04/20/technology/the-virtues-of-a-second-screen.html>

\*\*"Productivity, screens and aspect ratios", University of Utah, 2007 <https://collections.lib.utah.edu/details?id=214166>

# HOW TO CHOOSE?

Fellowes knows that your workspace needs to work for you. The extensive range of monitor arms and accessories we have developed means there is a solution for everyone. Finding the right specification for you is easy, just follow our simple 3-step guide to identify the most appropriate solution...



## WHY USE A MONITOR ARM?

- Easily adjust your monitors to the exact height, angle and distance to reduce strain on your neck, back and eyes
- Maximise your workspace and increase productivity
- Ideal for screen sharing or where one desk is used by multiple users

## 1. NUMBER OF SCREENS

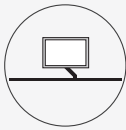

Single

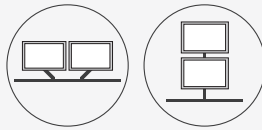

Dual vertical or horizontal

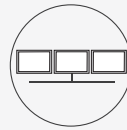

Triple



Laptop Arm Accessories

## 2. MOUNTING OPTION



Clamp or Grommet

Provides extra security and frees up vital desk space



Free Standing

Simple to set up and easy to move around

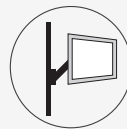

Wall Mounted

Perfect solution for meeting rooms or where desk space is limited

## 3. LEVEL OF MOVEMENT



Pole Mount

Allows you to choose a height setting and fix it in place



Gas Spring

Offers unlimited effortless adjustment

# UNDERSTANDING SPECIFICATIONS

## USB CONNECTIVITY

Work seamlessly with all your devices whilst remaining constantly connected with conveniently integrated USB ports.

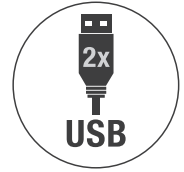

## ROTATION

Flexibility to rotate your monitor upto 360° and view your screen in either a landscape or portrait position.

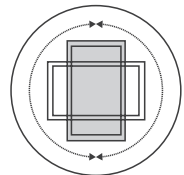

## PAN

Adjusting the monitor pan by angling the screen either inwards or outwards, allows you to easily achieve the correct position in front of you and reduce eyestrain. Especially useful where you are working with multiple screens.

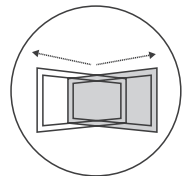

## TILT

Adjusting the monitor tilt upwards or downwards allows you to easily achieve the optimum angle of your screen for improved posture and decreased tension in your neck.

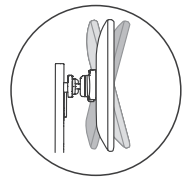

## FIRA COMPLIANCE

FIRA International are an independent Ergonomic Accreditor. This logo signifies that the relevant product complies with EU Health and Safety Legislation: BS EN ISO 9241 Ergonomic requirements for office work with visual display terminals (VDT's): Part 5: 1999, workstation layout and postural requirements.



## VESA COMPLIANCE

Most monitors have a VESA hole pattern on the back of the screen. VESA stands for Video Electronic Standard Association and is the industry benchmark used by worldwide manufactures of flat screen monitors.

On these VESA compliant screens you will find a square or a rectangle shaped group of 4 attachment holes, on the backside of the screen (such as one of the patterns illustrated in the diagram pictured).

Fellowes mounting solutions are all designed to fit these various VESA standards.

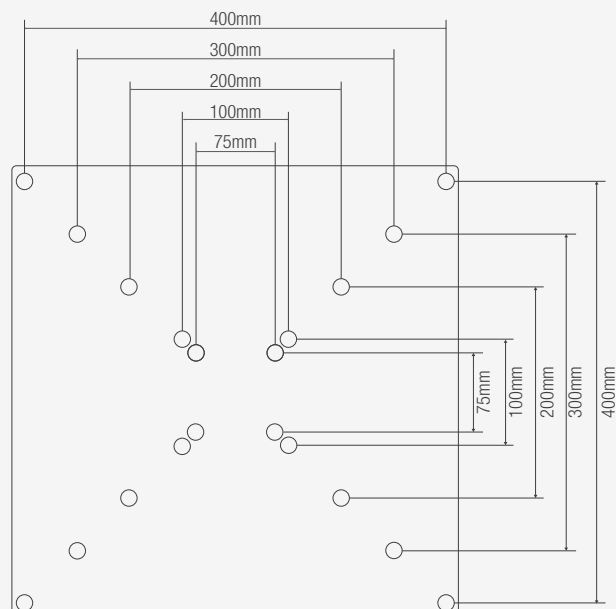



# PLATINUM SERIES MONITOR ARMS

View work differently by experiencing  
the benefits of gas spring adjustment  
and integrated USB connectivity.





# PLATINUM SERIES FEATURES

Enjoy a healthier working position and enhance productivity with Platinum Series monitor arms. Created to enhance desk users experience with their screens. The range offers effortless height and depth adjustments, as well as remarkable convenience with easy to reach access to USB connectivity.



**Ideal for desks with multiple users**  
Effortless monitor adjustment and collaborative working/sharing.

**Easy to mount**  
Use the grommet or clamp options depending on your set-up.



**Keep a clutter free workstation**  
with the intuitive cable management.





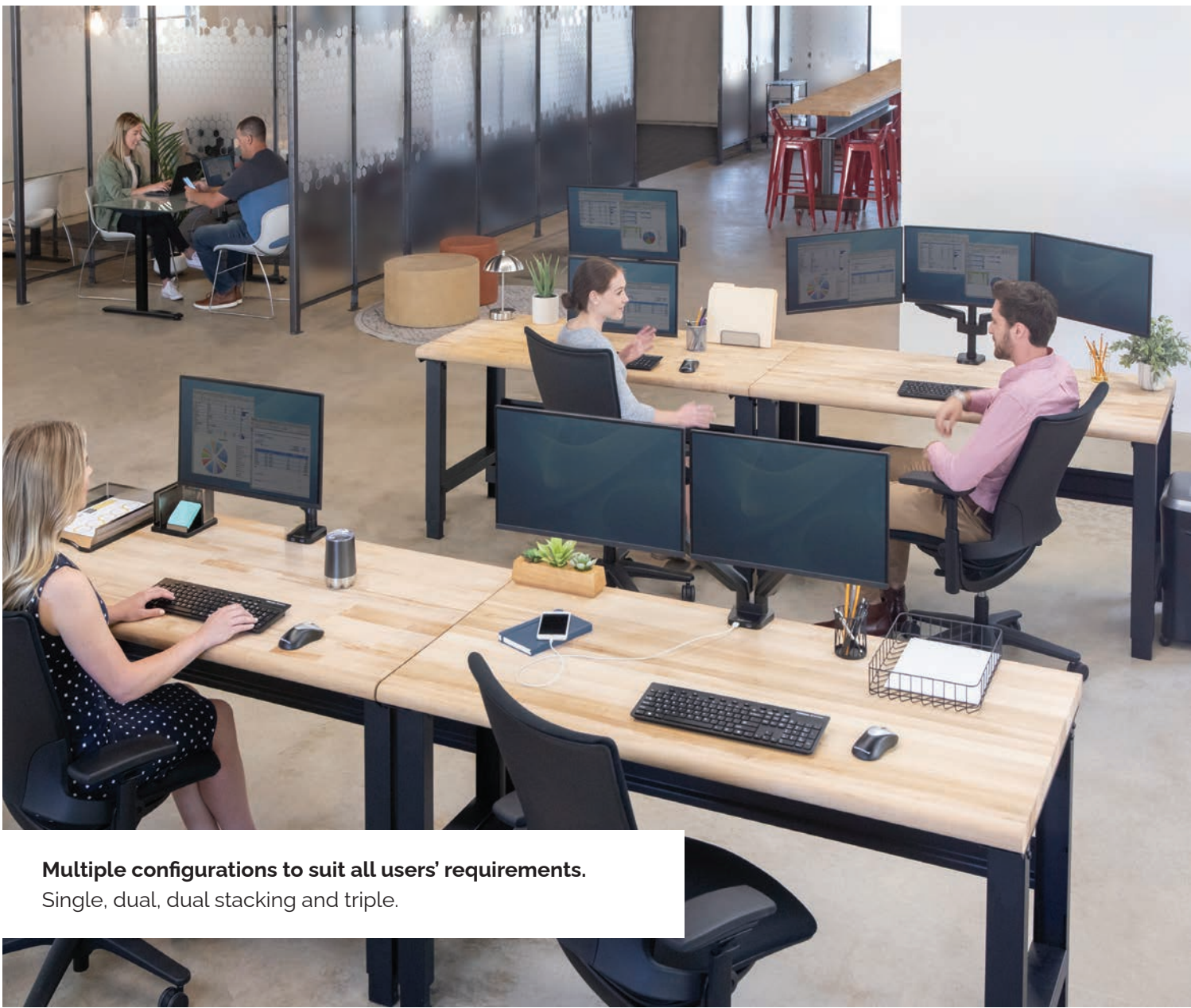

**Multiple configurations to suit all users' requirements.**  
Single, dual, dual stacking and triple.



**Built in USB 3.0 connectivity**  
(charging and data ports) making it easy to stay connected to your favorite devices.

# THE PLATINUM SERIES RANGE



	Single	Dual	Dual Stacking	Triple
Item Number	Black 8043301	Black 8042501	Black 8043401	Black 8042601
	White 8056201	White 8056301	-	-
	Silver 8056401	Silver 8056501	-	-
Product Dimensions (H x W x D)	590 x 114 x 495mm	590 x 949 x 114mm	886 x 103 x 115mm	924 x 1275 x 141mm
Product Weight	2.7kg	5.1kg	5.0kg	7.8kg
Height Adjustment Range	280mm	280mm	620mm	280mm
Height Adjustment Measurements	135 - 415mm	135 - 415mm	90 - 710mm	155 - 435mm
Pole Height	-	-	458mm	458mm
Reach Range	63.5 - 505mm	63.5 - 505mm	63.5 - 520mm	63.5 - 705mm
Rotation	360°			
Pan	180°			
Tilt	+/- 45°			
Arm Swivel	360°			
VESA	75 x 75 / 100 x 100			
Desk Compatibility	Desk Thickness: 10 - 85mm / Grommet Size: 8.5 - 70mm			
Tension Adjustments	Yes			
USB Connectivity	2 x 3.0 USB Port 0.5A (Type A)			
Weight Capacity	1.5 - 8kg	1.5 - 8kg per arm	1.5 - 8kg per arm	1.5 - 7kgs per arm
Maximum Monitor Size (diagonal)	32" (812mm)	32" (812mm)	32" (812mm)	27" (685mm)
Warranty	3 years limited			



Tested by FIRA International Ltd to comply with the ergonomic requirements set out in European Health and Safety Legislation: EN ISO 9241-5



# PROFESSIONAL SERIES MONITOR ARMS

The practical choice combining freestanding and pole mounted arms to ergonomically position your monitors and free up desk space.





# PROFESSIONAL SERIES FEATURES

Elevate your screen to increase valuable space and reduce eye, neck and shoulder strain. Freestanding design helps in those spaces that clamp or grommet may not be an option.

### Freestanding design

The easiest set up and ready to use solution.



### Enable the correct viewing position

Fully height adjustable.





**Multiple configurations to suit all users' requirements:**  
Single, dual, dual stacking and option for laptop users.



- **Enable the correct viewing position**  
Fully height and depth adjustable.

- **Easy to mount**  
Choose your preferred option between the clamp and grommet.



# THE PROFESSIONAL SERIES RANGE



	Single Freestanding	Dual Freestanding	Dual Stacking Freestanding
<b>Item Number</b>	8049601	8043701	8044001
<b>Product Dimensions (H x W x D)</b>	465 x 390 x 280mm	465 x 805 x 316mm	902 x 389 x 279mm
<b>Product Weight</b>	2.67kg	4.87kgs	4.08kgs
<b>Maximum Height</b>	465mm	465mm	905mm
<b>Rotation</b>	360°		
<b>Pan</b>	120°		
<b>Tilt</b>	+/- 45°	+/- 30°	+/- 45°
<b>VESA</b>	75 x 75 / 100 x 100		
<b>Weight Capacity</b>	8kgs	8kgs per arm	8kg per arm
<b>Maximum Monitor Size (diagonal)</b>	32" (812mm)	27" (685mm)	32" (812mm)
<b>Warranty</b>	3 years limited		



Tested by FIRA International Ltd to comply with the ergonomic requirements set out in European Health and Safety Legislation: EN ISO 9241-5





# REFLEX MONITOR ARMS

The entry-level range to ergonomically position your monitors and free up desk space.

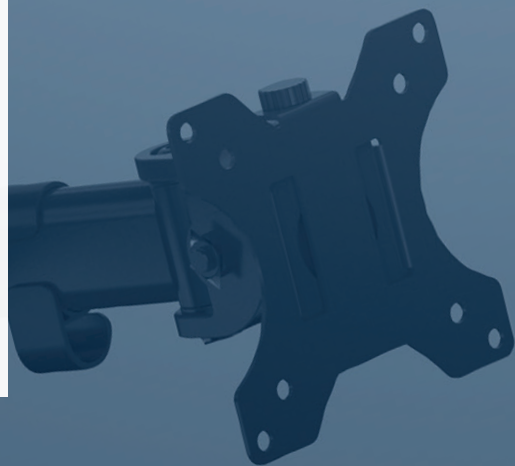

# REFLEX FEATURES

Elevate your screen to maximise desk space and reduce eye, neck and shoulder strain. The Reflex basic design offers height and depth adjustability while meeting the needs of modest budgets.



**Cable Management**  
Integrated to keep your workspace clutter free.







**Easy to mount**

Desk clamp and grommet mount included for secure and easy attachment options.





# THE REFLEX RANGE



	Reflex Single	Reflex Dual
Item Number	<b>Black:</b> 8502501	<b>Black:</b> 8502601
Product Dimensions (H x W x D)	550 x 116 x 490mm	550 x 116 x 726mm
Product Weight	3.0kg	4.2kg
Maximum Height	450mm	
Reach Range	63.5 - 422mm	63.5 - 387mm
Rotation	360°	
Pan	180°	
Tilt	+/- 45°	
Arm Swivel	180°	
VESA	75 x 75 / 100 x 100	
Desk Compatibility	Desk Thickness: 10 - 88mm   Grommet Size: 10.5 - 70mm	
Weight Capacity (kg)	8kg	8kg per arm
Maximum Monitor Size (diagonal)	32" (812mm)	27" (685mm)
Warranty	3 years limited	



Tested by FIRA International Ltd to comply with the ergonomic requirements set out in European Health and Safety Legislation: EN ISO 9241-5



# WALL MOUNT MONITOR ARMS

Securely mount screens and TVs  
to the wall.

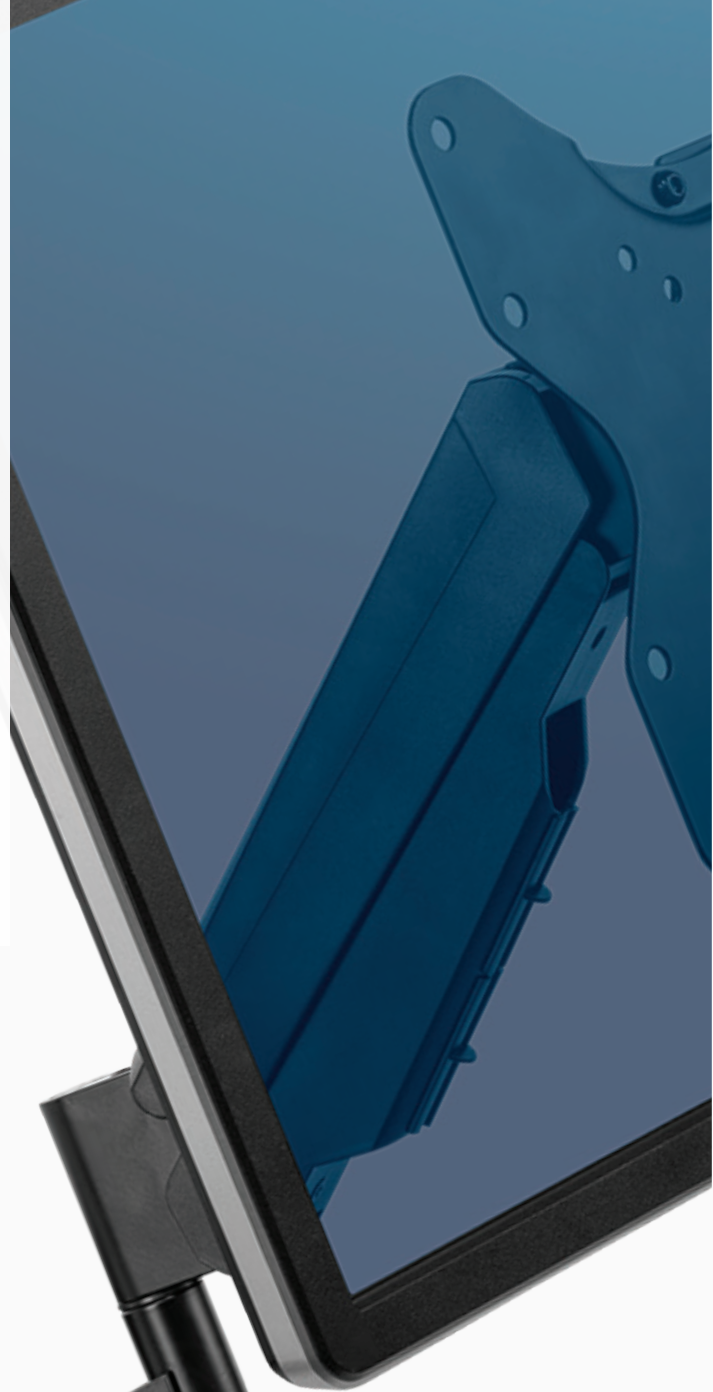



## THE WALL MOUNT RANGE



	Single Wall Mount Arm	Full Motion Wall Mount Arm
<b>Item Number</b>	<b>Black:</b> 8043501	<b>Black:</b> 8043601
<b>Product Dimensions (H x W x D)</b>	478 x 225 x 514mm	454 x 413 x 502mm
<b>Product Weight</b>	3.54kg	2.72kg
<b>Height Adjustment Range</b>	282mm	-
<b>Reach Range</b>	495mm	495mm
<b>Rotation</b>	+/- 3°	360°
<b>Pan</b>	+/- 90°	+/- 90°
<b>Tilt</b>	+5°/-15°	+2°/-12°
<b>Arm Swivel</b>	180°	180°
<b>VESA</b>	75 x 75 / 100 x 100 / 200 x 200 / 200 x 100	100 x 100 / 100 x 150 / 200 x 100 / 200 x 200 / 300 x 300 / 300 x 200 / 400 x 400 / 400 x 300 / 400 x 200
<b>Weight Capacity (kg)</b>	5 - 30kg	34.9kg
<b>Maximum Monitor Size (diagonal)</b>	20" - 42" (508 - 1066mm)	23" - 55" (584 - 1397mm)
<b>Warranty</b>	3 years limited	3 years limited



# A SOLUTION FOR **LAPTOP USERS**



## Laptop Arm Accessory

Attach your laptop to a monitor arm to increase desk space and position your laptop ergonomically, reducing eye, neck and shoulder strain

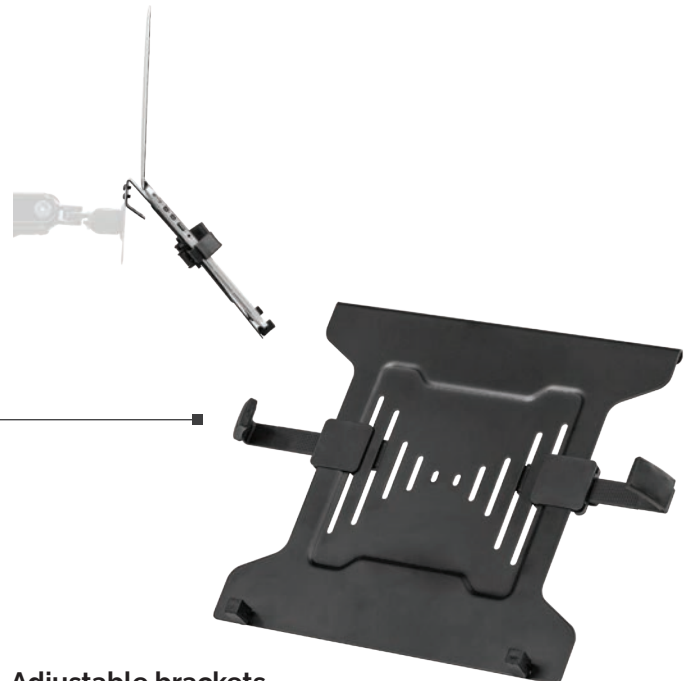

**Adjustable brackets**  
keep your laptop secure

Compatible with all Fellowes monitor arms excluding the Professional Series Clamp monitor arms (8041601/8041701).

	Laptop Arm Accessory
Code	Black: 8044101
Colour	Black:
Product Dimensions (H x W x D)	279.4 x 442.9 x 65.1mm
Product Weight	1.18kg
Weight Capacity (kg)	4.5kg
Maximum Laptop Size (diagonal)	17" (431mm)
VESA	75 x 75 / 100 x 100
Warranty	3 years limited



Tested by FIRA International Ltd to comply with the ergonomic requirements set out in European Health and Safety Legislation: EN ISO 9241-5



To contact a Fellowes® service representative,  
call 1800 33 11 77 or visit us on the web at  
[www.fellowes.com/au](http://www.fellowes.com/au)  
79-81 South Centre Road,  
Melbourne Airport Business Park,  
Tullamarine VIC 3045 Australia

This publication is produced on Silk FSC® certified paper, supporting responsible use of forest resources.