

The **UGS Clear Span** Structural Glazing system is a unique patented system that is designed to provide a simple and effective universal mounting and sealing method for various glazing materials, such as glass, polycarbonate (solid sheet or structured/twinwall/tri-wall), or acrylic.

This system utilises a top-cap compression clamping method to provide a positive clamping pressure onto the glazing material to achieve an effective weather tight seal by utilising the compressed double-lip TPV seal, and accommodates glazing sheets ranging in thickness from 4mm up to 16mm.

The **ClearSpan glazing bar** assemblies are available in 2 standard lengths, 4050mm and 6050mm, with either powdercoat or natural aluminium finish. Each glazing bar assembly is supplied with the following components: glazing bar base extrusion, top cap extrusion, top cap infill extrusion, stainless steel top cap compression screws, end plates (with screws, 2 per bar assembly) plus rubber gaskets.

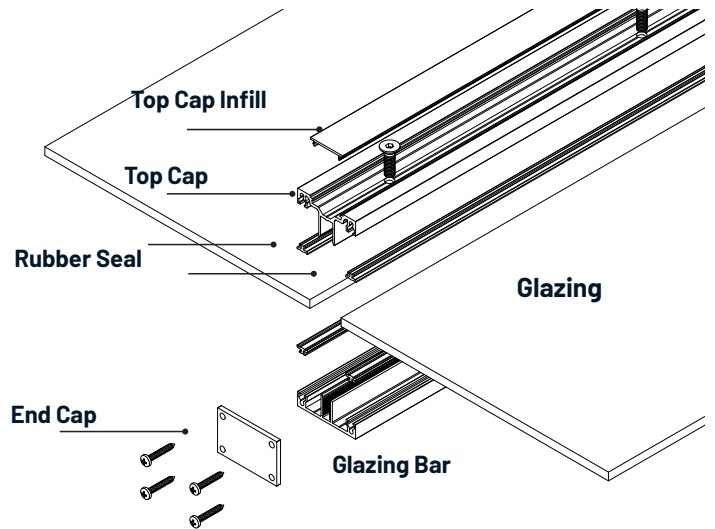

Thermal expansion

Allow 3-5mm per lineal metre of glazing panel for polycarbonate and acrylic solid sheet.

#F150-Bar-4050 Glazing bar assembly 4050mm
#F150-Bar-6050 Glazing bar assembly 6050mm

ADDITIONAL COMPONENTS

Bar End Caps

Attached to the end of the glazing bar assembly for the purpose of capping the extrusions and preventing rubber seals and glazing from migrating out due to thermal expansion. Made from aluminium and powdercoated to match. Available to suit 4mm-16mm glazing thickness. Supplied with stainless steel self-tapping end capscrews.

6mm Bar End Caps*
#BC-6-PC

8mm Bar End Caps*
#BC-8-PC

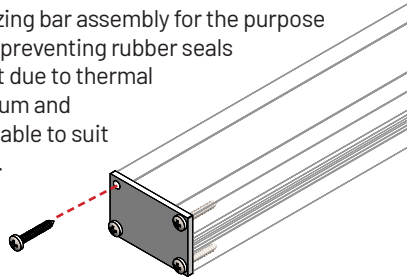

Edge Spacers

Designed to fit in the glazing bar assembly at the edges of the roof structure. Supplied in either natural aluminium or powdercoat finish. These should be matched to the glazing thickness (ie 6mm glass would require a 6mm edge spacer). Available in lengths of 4050mm or 6050mm.

6mm Edge Spacers*
#ES6-4050-PC (4050mm)
#ES6-6050-PC (6050mm)

8mm Edge Spacers*
#ES8-4050-PC (4050mm)
#ES8-6050-PC (6050mm)

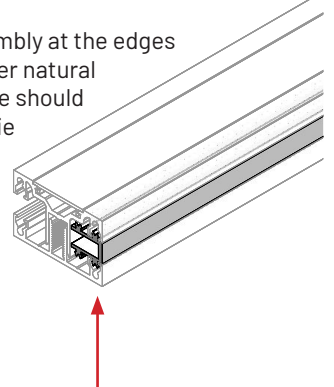

Fixing Fasteners

Used for attaching the glazing bar (base) to timber, steel or aluminium support structure, ie purlins or rafters. Please note, these **are not** included in the glazing bar assemblies.

10-gauge 20mm self-drill tek-screw
#FS10GX20-SDTS (100pk)

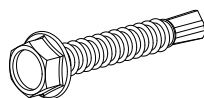

10-gauge 35mm square pan head self-tapping screw
#FS10GX35-PHST (100pk)

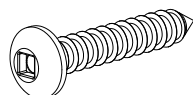

Top Cap Compression Screws

M6 stainless steel counter-sunk screws are used to compress the glazing bar and rubber seals against the glazing sheet. Please note these **are** included with glazing bar assemblies.

20mm to suit 4 and 6mm glazing
#CS6X20 (100pk)

25mm to suit 8,10 and 12mm glazing
#CS6X25 (100pk)

30mm to suit 16mm glazing
#CS6X30 (100pk)

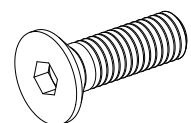

*Other sizes available. To view our full range of component and part sizes, please visit our website.

1. Cut glazing bars to length

Cut the glazing bars (base, top-cap and infill) to the required length. Consider thermal expansion of plastic glazing sheets in your glazing bar length. Most solid polycarbonates and acrylic sheets require 3-5mm per lineal metre. Also consider allowing a 50mm overhang if you are fitting a gutter.

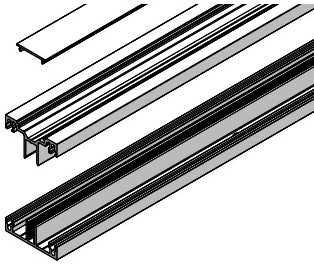

2. Prepare Top Caps

Drill 7mm diameter holes at approx 300mm centres, starting 100mm from the end. Insert the rubber gaskets into the slots and trim to the length of the glazing bar. **Note:** Insert only 1x rubber gasket in the glazing bar that is located at the end(s) of the roof, as the vacant slot will have an aluminium edge spacer inserted.

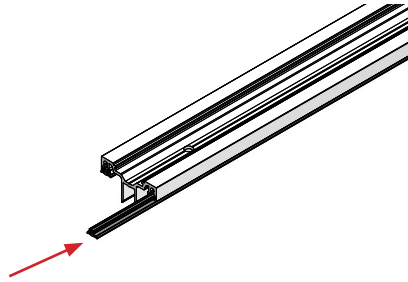

3. Prepare Base Bars

Slide rubber into the grooves of the base bars. Drill 2x 7mm holes each side of the base bar, in locations that align with the purlin spacing. If you are attaching along rafters drill 2x 7mm diameter holes (each side of the glazing bar), every 500mm. **Note:** It is important to note the max maximum purlin distance is adhered to for your specific location/wind zone. Refer to the UGS website span chart for details.

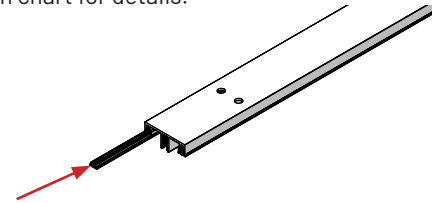

4. Attach the glazing bar base to purlins or rafters

Attach glazing bar (base) to purlins and brackets or rafters using the 10G x 35mm (Part no. #FS10GX35-PHST) timber fixing screws. If attaching to steel or aluminium, use 10g x 20mm self-drilling tek-screw. (Part no. #F10GX20-SDTS). Ensure bars are securely fastened with appropriate centres to suit glazing sheet width. To calculate glazing bar centres, use the following formula: glazing sheet width + 20mm.

Purlin

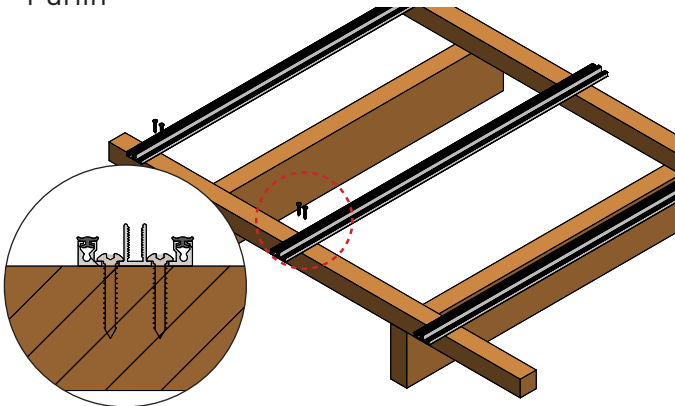

Rafter

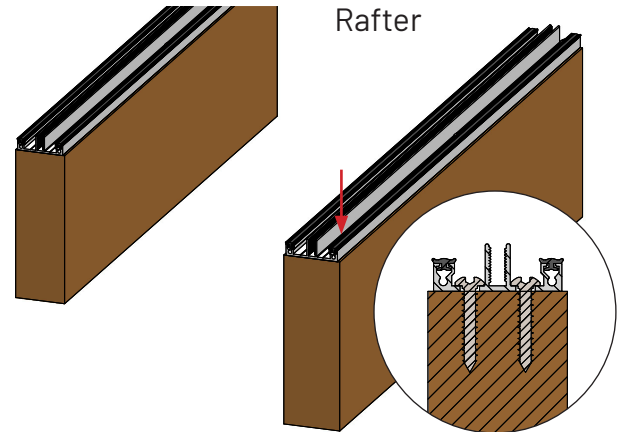

5. Insert Glazing Sheet

Position the glazing sheets into their resting position on the rubber gasket/glazing bar, ensuring the sheet is centrally located and in its correct position.

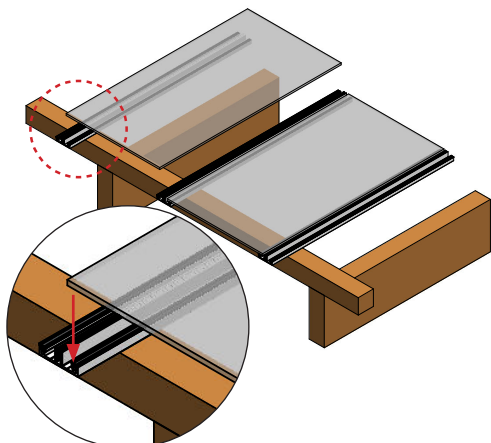

6. Fit to Caps

Insert the stainless steel countersunk compression screws (provided) through the 7mm diameter holes in the glazing bar top cap. Using the 4mm hex driver tighten the screws to compress the glazing bar top cap and rubber gaskets against the glazing sheet. Be careful not to over tighten. The recommended torque is 6Nm (4.4ft/Lbs) max.

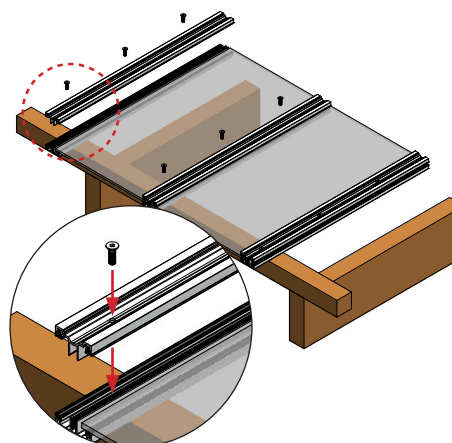

7. Insert infill and fit end plates

Ensure the top cap infill is cut to the same length of the top cap. Then insert either by sliding it in from the end, or alternatively gently tapping it in from the top using a soft face hammer/mallet. Fit the end plates to the end of the extrusion assembly using the 4x self-taping screws provided.

